

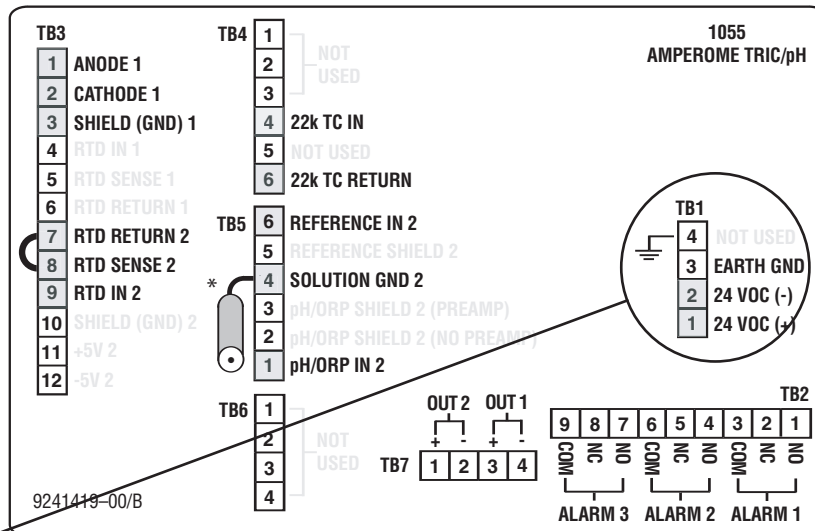

# Quick Start Guide 30-A-pH/DO-24

## STEP 1: Wire sensor(s) and power supply to the analyzer.

1. Take the rear cover off of the analyzer by removing the 4 screws with a Phillips screwdriver.



Wiring Connections for Model 30 (Panel Mount with 24V DC)

2. Attach the Power Supply Cable: Remove the plastic tag from TB1. Connect the positive wire to 24 VOC (+) (TB1-1). Connect the negative wire to 24 VOC (-) (TB1-2).

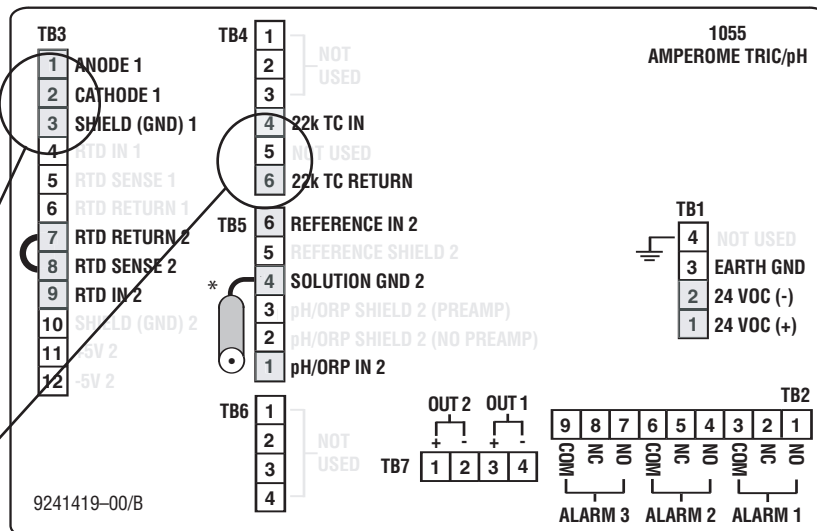

Wiring Connections for Model 30 (Panel Mount with 24V DC)

3. Attach the D.O. Sensor Cable: Connect the red wire (ANO) to ANODE 1 (TB3-1). Connect the white wire (CATH) to CATHODE 1 (TB3-2). Connect the green wire (SHLD) to SHIELD 1 (TB3-3). Connect the brown wire (TC) to 22k TC IN (TB4-4). Connect the black wire (TC) to 22k TC RETURN (TB4-6).

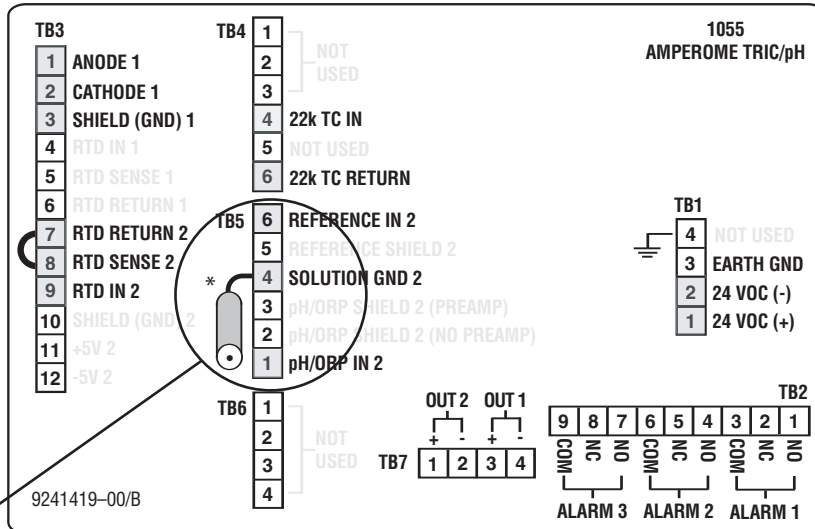

**Wiring Connections for Model 30 (Panel Mount with 24V DC)**

4. Attach the pH Electrode Cable: Connect the black wire (REF) to REFERENCE IN 2 (TB5-6). \*Connect the green wire (GRND) to the 1 mΩ resistor socket factory installed in SOLUTION GRND 2 (TB5-4). Connect the clear wire (pH) to pH/ORP IN 2 (TB5-1).

CAUTION: Unit will not operate properly if the 1 mΩ resistor socket is removed from terminal (TB5-4).

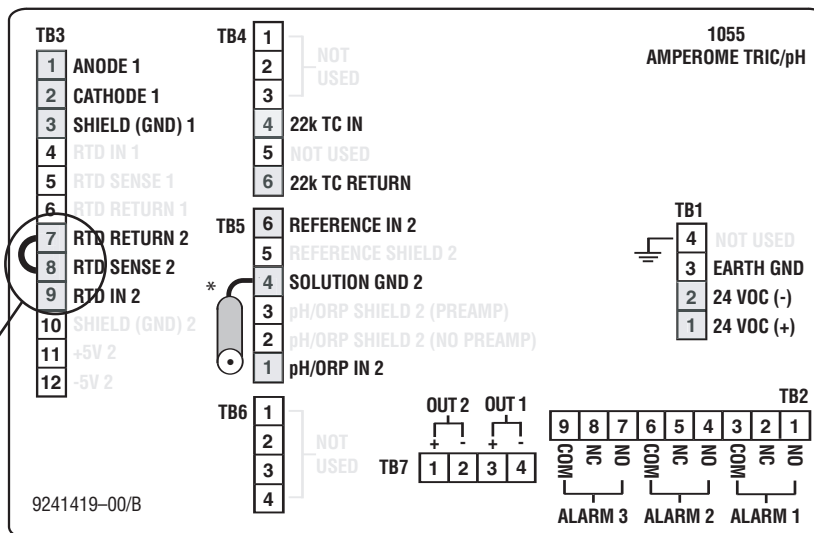

**Wiring Connections for Model 30 (Panel Mount with 24V DC)**

5. Attach the Pt 100(0) RTD Cable: Connect the red wire (TC) to RTD RETURN 2 (TB3-7). Connect the black wire (TC) to RTD IN 2 (TB3-9). These wires will join the black “JUMPER” wire factory installed across (TB3-7 and TB3-8).

6. Once connections are secured and verified, apply power to the analyzer.

**STEP 2: Attaching two sensors - Configure analyzer for language, sensors and units. (Skip this step if attaching only one sensor to the analyzer.)**

When powered up for the first time, Quick Start screens appear in the analyzer's display. Using Quick Start is easy:

- i. A blinking field shows the position of the cursor.
- ii. Use the ◀ or ▶ key to move the cursor left or right. Use the ▲ or ▼ key to move the cursor up or down or to increase or decrease the value of a digit. Use the ▲ or ▼ key to move the decimal point.
- iii. Use the ▲ key to scroll between display screens, or when a fault is displayed for information about the fault.
- iv. Press ENTER to store a setting. Press EXIT to leave without storing changes. Pressing EXIT also returns the display to the previous screen.
- v. If the power to the analyzer is interrupted, the eeprom battery backup in the instrument will save the last stored configuration.

<pre>English  Francais Español  &gt;&gt;</pre>	<p>1. Choose the desired language. Select &gt;&gt; to show more choices. Press ENTER when your language is blinking. These instructions are based on the choice of ENGLISH.</p>
<pre># of sensors? One          Two</pre>	<p>2. Choose the number of sensors wired to the analyzer. Press ENTER when TWO is blinking. If you only have one sensor connected, goto QUICK START STEP 3 or QUICK START STEP 4.</p>
<pre>S1 Manufacturer? Rosemount Other</pre>	<p>3. For Sensor 1, which is dedicated to Dissolved Oxygen (D.O.), identify the manufacturer of the sensor, Rosemount Analytical or other. For Broadley-James sensors, choose OTHER.</p>
<pre>S1 units in? ppm          %sat</pre>	<p>4. Select the desired units for Sensor 1. Press ENTER when %SAT is blinking.</p>
<pre>S2 Measure?  pH Redox        ORP</pre>	<p>5. Choose pH, Redox, or ORP for Sensor 2. Press ENTER when PH is blinking.</p>
<pre>Temperature in? °C           °F</pre>	<p>6. Choose temperature units. Press ENTER when °C is blinking</p>
<pre>xx.x %sat xx.x°C  x.xx pH</pre>	<p>7. The analyzer is now set up to run and the main default display appears.</p>

Also Note:  
The outputs and alarms are assigned to default values. To change settings, refer to Section 5.0, Programming the Analyzer. To reinstall factory settings and return to Quick Start, see Section 5.10.



**STEP 3: Attaching one D.O. sensor** - Configure analyzer for language, sensor and units. (Skip this step if attaching a pH sensor to the analyzer.)

<pre>English Francais Español    &gt;&gt;</pre>	<p>1. Choose the desired language. Select &gt;&gt; to show more choices. Press ENTER when your language is blinking. These instructions are based on the choice of ENGLISH.</p>
<pre># of sensors? One        Two</pre>	<p>2. Choose the number of sensors wired to the analyzer. Press ENTER when ONE is blinking. Choosing One configures the analyzer as a dissolved oxygen analyzer.</p>
<pre>S1 Manufacturer? Rosemount Other</pre>	<p>3. For Sensor 1, which is dedicated to Dissolved Oxygen (D.O.), identify the manufacturer of the sensor, Rosemount Analytical or other. For Broadley-James sensors, choose OTHER.</p>
<pre>S1 units in? ppm        %sat</pre>	<p>4. Select the desired units for Sensor 1. Press ENTER when %SAT is blinking.</p>
<pre>Temperature in? °C         °F</pre>	<p>6. Choose temperature units. Press ENTER when °C is blinking</p>
<pre>xx.x %sat xx.x°C   x.xxmA</pre>	<p>7. The analyzer is now set up to run and the dissolved oxygen display appears.</p>

**STEP 4: Attaching one pH sensor - Configure analyzer for language, sensor and units.**

<p>English Francais Espanol &gt;&gt;</p>	<p>1. Choose the desired language. Select &gt;&gt; to show more choices. Press ENTER when your language is blinking. These instructions are based on the choice of ENGLISH.</p>
<p># of sensors? One Two</p>	<p>2. Choose the number of sensors wired to the analyzer. Press ENTER when TWO is blinking. Sensor 1 will be removed from the display after the default display appears.</p>
<p>S1 Manufacturer? Rosemount Other</p>	<p>3. For Sensor 1, which is dedicated to Dissolved Oxygen (D.O.), identify the manufacturer of the sensor, Rosemount Analytical or other. For Broadley-James sensors, choose OTHER.</p>
<p>S1 units in? ppm %sat</p>	<p>4. Select the desired units for Sensor 1. Press ENTER when %SAT is blinking.</p>
<p>S2 Measure? pH Redox ORP</p>	<p>5. Choose pH, Redox, or ORP for Sensor 2. Press ENTER when pH is blinking.</p>
<p>Temperature in? °C °F</p>	<p>6. Choose temperature units. Press ENTER when °C is blinking</p>
<p>xx.x %sat xx.x°C x.xx pH</p>	<p>7. The analyzer is now set up to run and the main default display appears.</p>
<p>Calibrate Hold Program Display</p>	<p>8. Press MENU to get the main screen to appear. Press ENTER when DISPLAY is blinking.</p>
<p>Default Display Language Contrst</p>	<p>9. Press ENTER when DEFAULT DISPLAY is blinking.</p>
<p>xx.x% sat xx.x°C x.xx pH</p>	<p>10. Press ▲ 3 times until the display for sensor 2 appears and then press ENTER.</p>
<p>Default Display Language Contrst</p>	<p>11. Press EXIT 2 times to go back to the main display.</p>
<p>S2 x.xx pH xx.x°C xxxxxmV</p>	<p>12. The analyzer is now set up to run and the pH display appears.</p>

**STEP 5: Calibrating two sensors** - All sensors and temperature controllers must be attached to the analyzer before beginning this step.

<p>Calibrate Hold Program Display</p>	<p>1. Press MENU for the main menu screen. Choose CALIBRATE.</p>
<p>Calibrate? Sensor1 Sensor2</p>	<p>2. Choose Sensor1 (D.O.) or Sensor2 (pH). To start with Sensor1, press ENTER when SENSOR1 is blinking.</p>
<p>Cal Sensor1? Measurement Temp</p>	<p>3. Choose MEASUREMENT.</p>
<p>Cal S1? AirCal InProgress Zero</p>	<p>4. The D.O. sensor can easily be calibrated in air, so choose AIRCAL.</p>
<p>S1 Air Calibrate Press: 754mmHg</p>	<p>5. There is a pressure sensor inside the analyzer. If the reading is wrong, enter the correct value. Press ENTER when the correct barometric pressure is displayed.</p>
<p>S1 Live xx.x%sat AirCal wait</p>	<p>6. The top line shows the current dissolved oxygen reading, while the D.O. sensor measures the concentration of oxygen in the air (this is the full-scale standard). WAIT will blink while the analyzer is gathering its data.</p>
<p>S1 Live 100%sat AirCal Done</p>	<p>7. This screen will appear when the air calibration is done and the analyzer has stored the current reading to 100% saturation. Press ENTER to continue to the zero calibration.</p>
<p>Calibrate? Sensor1 Sensor2</p>	<p>8. Choose SENSOR1 again.</p>
<p>Cal S1? AirCal InProgress Zero</p>	<p>9. The D.O. can be zeroed by detaching the cable from the sensor. Detach the cable first, then press ENTER when ZERO is blinking. (This can also be accomplished by using oxygen-free nitrogen instead of detaching the cable.)</p>
<p>S1 Live xx.x%sat Zeroing wait</p>	<p>10. The top line shows the current dissolved oxygen reading. The analyzer is measuring 0% saturation since there is no sensor attached. WAIT will blink while the analyzer is gathering its data.</p>
<p>S1 Live 00.0%sat Sensor Zero Done</p>	<p>11. Once the reading is stable, this screen will appear. Sensor zero is complete and the analyzer has stored the current reading as zero. Press ENTER to continue to the next step and then reattach the D.O. sensor.</p>
<p>Calibrate? Sensor1 Sensor2</p>	<p>12. Choose Sensor1 (D.O.) or Sensor2 (pH). To continue with Sensor2, press ENTER when SENSOR2 is blinking.</p>

(continued on the next page)

**STEP 5: (continued)**

<pre>Cal Sensor2? Measurement Temp</pre>	<p>13. Choose MEASUREMENT.</p>
<pre>S2 Standardize Slope BufferCal</pre>	<p>14. The pH electrode can easily be calibrated in buffers of pH 4 and 7, so choose BUFFERCAL.</p>
<pre>S2 Buffer Cal? Auto Manual</pre>	<p>15. Choose MANUAL to do the buffer calibrations so that the pH of each buffer can be entered manually.</p>
<pre>S2 Manual Cal? Buffer1 Buffer2</pre>	<p>16. Rinse the pH electrode and temperature controller with water and place them in buffer 1 (pH 4). Be sure that the glass bulb is completely submerged. Press ENTER when BUFFER1 is blinking.</p>
<pre>S2 Live xx.xpH Buf1 04.00pH</pre>	<p>17. The top line shows the actual buffer reading from the pH electrode. Change the pH in the second line to the pH of the buffer solution (4.00pH). Wait until the actual reading is stable and then press ENTER.</p>
<pre>S2 Manual Cal? Buffer1 Buffer2</pre>	<p>18. Rinse the pH electrode and temperature controller with water and place them in buffer 2 (pH 7). Be sure that the glass bulb is completely submerged. Press ENTER when BUFFER2 is blinking.</p>
<pre>S2 Live xx.xpH Buf2 10.00pH</pre>	<p>19. The top line shows the actual buffer reading from the pH electrode. Change the pH in the second line to the pH of the buffer solution (7.00pH). Wait until the actual reading is stable and then press ENTER</p>
<pre>S2 offset xmV Slope xxmV@25C</pre>	<p>20. If the calibration was successful, the analyzer will display the offset and the slope (at 25°C). The display will then return to the original calibration screen. If the calibration was unsuccessful, Calibration Error will appear.</p>
<pre>Calibrate? Sensor1 Sensor2</pre>	<p>21. To return to the main menu screen press EXIT.</p>
<pre>Calibrate Hold Program Display</pre>	<p>22. To return to the main display press EXIT again.</p>
<pre>xx.x %sat xx.x°C x.xx pH</pre>	<p>23. The analyzer is now set up to run and the main default display appears.</p>