

ESSENTIAL INSTRUCTIONS

READ THIS PAGE BEFORE PROCEEDING!

This product has been designed, manufactured, and tested to meet many national and international standards. Because these instruments are sophisticated technical products, you must properly install, use, and maintain them to ensure they continue to operate within their normal specifications. The following instructions must be adhered to and integrated into your safety program when installing, using, and maintaining these products. Failure to follow the proper instructions may cause any one of the following situations to occur: Loss of life; personal injury; property damage; damage to this instrument; and warranty invalidation.

- Read all instructions prior to installing, operating, and servicing the product. If this Instruction Manual is not the correct manual, telephone (714) 829-5555 and the requested manual will be provided. Save this Instruction Manual for future reference.
- If you do not understand any of the instructions, contact your Broadley-James representative for clarification.
- Follow all warnings, cautions, and instructions marked on and supplied with the product.
- Inform and educate your personnel in the proper installation, operation, and maintenance of the product.
- Install your equipment as specified in the Installation Instructions of the appropriate Instruction Manual and per applicable local and national codes. Connect all products to the proper electrical and pressure sources.
- To ensure proper performance, use qualified personnel to install, operate, update, program, and maintain the product.
- When replacement parts are required, ensure that qualified people use replacement parts specified by Broadley-James. Unauthorized parts and procedures can affect the product's performance and place the safe operation of your process at risk. Look alike substitutions may result in fire, electrical hazards, or improper operation.
- Ensure that all equipment doors are closed and protective covers are in place, except when maintenance is being performed by qualified persons, to prevent electrical shock and personal injury.

WARNING

ELECTRICAL SHOCK HAZARD

Making cable connections to and servicing this instrument requires access to shock hazard level voltages which can cause death or serious injury.

Relay contacts made to separate power sources must be disconnected before servicing.

Electrical installation must be in accordance with the National Electrical Code (ANSI/NFPA-70) and/or any other applicable national or local codes.

Unused cable conduit entries must be securely sealed by non-flammable closures to provide enclosure integrity in compliance with personal safety and environmental protection requirements.

For safety and proper performance this instrument must be connected to a properly grounded three-wire power source.

Proper relay use and configuration is the responsibility of the user.

Do not operate this instrument without front cover secured. Refer installation, operation and servicing to qualified personnel.

P1674 REV. A
Jan. 1997

Broadley-James Corporation
19 Thomas
Irvine, CA 92718 USA
Tel: (949) 829-5555



MODEL 20-03 MICROPROCESSOR D.O. TRANSMITTER

TABLE OF CONTENTS

Section	Title	Page
1.0	DESCRIPTION AND SPECIFICATIONS	1
1.1	General Description	1
1.2	Performance Specifications	1
1.3	Physical Specifications	1
1.4	Ordering Information	2
2.0	INSTALLATION	3
2.1	Unpacking and Inspection	3
2.2	Mechanical Installation	3
2.2.1	Panel Mounting	3
2.2.2	Wall Mounting	3
2.2.3	Pipe Mounting	4
2.3	Electrical Wiring	4
2.3.1	Power Input Wiring	4
2.3.2	Output Wiring	4
2.3.3	Sensor	4
2.4	EMC Installation Guidelines	4
2.4.1	Screening & Earthing	12
2.4.2	Summary of EMC Guidelines	12
3.0	DESCRIPTION OF CONTROLS	13
3.1	Keyboard Functions	13
3.2	Keyboard Routine	17
3.2.1	Read Only Function	17
3.2.2	Set Functions	17
3.2.3	Entering Numerical Values	17
4.0	CONFIGURATION	19
4.1	General	19
4.1.1	Set Mode	19
4.1.2	Configuration Work Sheet	19
4.1.3	Barometric Pressure	19
4.1.4	Transmitter Zero	19
4.1.5	Sensor Input	19
4.2	Alarm 1 and 2	22
4.3	Interval Timer	24
4.4	Temperature Configuration	26
4.5	Current Output	28
4.6	Dissolved Oxygen Range Units	30
4.7	Barometric Pressure Units	32
4.8	Solubility Correction Factor	34
4.10	Defaults	36
4.11	Software Version Number	38
4.12	Display Test	38
4.13	Alarm Setpoint	39
4.14	Output Scale Expansion	40
4.15	Output Display/Output Simulation	41
4.16	Hold	41

TABLE OF CONTENTS CONT'D.

Section	Title	Page
5.0	START-UP AND CALIBRATION	43
5.1	General	43
5.2	Start-up	43
5.3	Calibration	43
5.3.1	Temperature Calibration	43
5.3.2	Transmitter Zero	44
5.3.3	ppm Calibration	45
5.3.3.1	Air Calibration	45
5.3.3.2	Grab Sample ppm Standardization	45
5.3.4	% Saturation Calibration	46
5.3.4.1	Air Calibration	46
5.3.4.2	Update Barometric Pressure	46
5.3.4.3	% Saturation Standardization	46
5.4	Calibration for Fermentation Applications	47
6.0	KEYBOARD SECURITY	48
6.1	Keyboard Security	48
7.0	THEORY OF OPERATION	49
7.1	General	49
7.1.1	Basic DO Measurement	49
7.2	Measurement Variables	49
7.2.1	Barometric Pressure and Relative Humidity	49
7.2.2	Relative Humidity	49
7.2.3	Sample Temperature	50
7.2.4	Interfering Gases	50
7.2.5	Composition of the Liquid Medium	50
8.0	DIAGNOSTICS AND TROUBLESHOOTING	51
8.1	Diagnostics	51
8.1.1	Fault Mnemonics	51
8.1.2	Temperature Compensation	51
8.2	Troubleshooting.....	52
8.2.1	Installation Failure	52
8.2.2	Display Test	52
8.2.3	Software Version	52
8.2.4	Sensor Troubleshooting	52
8.2.5	CPU Board Replacement	52
8.2.6	Power Board Replacement	52
9.0	RETURN OF MATERIALS	54
9.1	General	54
9.2	Warranty Repair	54
9-3	Non Warranty Repair	54

TABLE OF CONTENTS CONT'D.

LIST OF FIGURES

Figure No.	Title	Page
2-1	Panel Mounting Cutout	5
2-2	Panel Mounting Latch Installation	6
2-4	Wall Mounting J-Box Installation	7
2-5	Wall Mounting J-Box Wiring	8
2-6	Pipe Mounting Installation	9
2-7	Electrical Wiring	10
2-8	Sensor Wiring	11
2-9	Recommended Minimum Cable Separation Guidelines	12
3-1	Keyboard Overlay	16
4-1	Set Function Menu	20
4-2	Alarm 1 and Alarm 2 Setup	23
4-3	Interval Timer Setup	25
4-4	Temperature Configuration Setup	27
4-5	Current Output Setup	29
4-6	Dissolved Oxygen Units Setup	31
4-7	Barometric Pressure Setup	33
4-8	Solubility Correction Factor Setup	35
4-10	Default Setup	37
4-11	Alarm Setpoint	39
4-12	Output Scale Expansion	40
5-1	DO Standardization Formula	45

LIST OF TABLES

Table No.	Title	Page
3-1	Key Description	17
3-2	Information Mnemonics	18
3-3	Set Function Mnemonics	18
4-1	Configuration Worksheet	21
8-1	Fault Mnemonics	51
8-2	Thermistor Resistance Values	51
8-3	Troubleshooting Guide	53
8-4	Replacement Parts and Accessories	53

NOTES

SECTION 1.0 DESCRIPTION AND SPECIFICATIONS

1.1 GENERAL DESCRIPTION. The MODEL 20-03 DO Microprocessor Transmitter with the OxyProbe® dissolved Oxygen sensors, are designed to continuously measure and control dissolved oxygen, in industrial, biopharmaceutical, beverage, and food processes.

Housed in a NEMA 4X (IP65) weatherproof corrosion-resistant flame retardant enclosure, the MODEL 20-03 is suitable for panel, pipe or wall mounting. All functions are accessed through the front panel membrane keyboard which features tactile feedback.

The MODEL 20-03 transmits a user selected isolated current output continuously expandable over the measurement range in either Direct or Reverse and can be displayed in milliamps or percent. Output dampening is user selectable.

Dual programmable alarms are standard for either high or low operation. Alarm 2 may be programmed as a fault alarm. Both alarms feature independent setpoints, adjustable hysteresis and time delay action. The time delay is convenient when an alarm is used for corrective action. Time delay will ignore a temporary upset and prevent shutting down a process. An interval timer with relay is also provided.

Automatic or manual temperature compensation is keyboard selectable. The process temperature is accurately measured at the sensor and read on the display. For greater accuracy, the temperature indication may be standardized to the process temperature. The temperature may be configured to read in °C or °F.

1.2 PERFORMANCE SPECIFICATIONS

Operating Range: 0-29.99 ppm (mg/L), 0-299.99 % saturation. 0-80°C

Repeatability: ±0.1% of range.

Accuracy: ±1% full scale (< 3% of actual readout).

Stability: Zero Drift: ±1% full scale/month.
Span Drift: ±1% full scale/month.

Response Time: 0-95% full scale in less than 15 seconds.

Ambient Temperature: -10 to 65°C (14 to 149°F).

Relative Humidity: 0-95% humidity.

Temperature Compensation: 0-80°C.

Alarms: Dual, field selectable
High/Low, High/High, Low/Low
Third relay used for timer.

Current Output: Isolated, Direct or Reverse,
0-20 mA or 4-20 mA DC into 600 ohms
maximum load.

1.3 PHYSICAL SPECIFICATIONS

DIN Enclosure: Black, ABS, NEMA 4X, IP65.
CSA enclosure 4.

DIN Dimensions: 144 X 144 X 192mm
(5.7 X 5.7 X 7.6 inches).

Front Panel: Membrane keyboard with tactile feedback and user selectable security. Black and white on grey.

Electrical Classification:

Group I Panel Mount Enclosure:

FM Class I, Div. 2 Groups A thru D
28 VDC relays - 6.0 amps resistive only
150 mA - Groups A & B; 400 mA - Group C;
540 mA - Group D; Ci - 0; Li - 0

CSA Class I, Div. 2 Groups A thru D
28 VDC, 110 Vac & 230 Vac relays
6.0 Amps resistive only.

Power Requirements: 115 Vac, ±10%, 50/60 Hz
±6%, 4.0 W.
230 Vac, ±10%, 50/60 Hz
±6%, 4.0 W.

EMI/RFI:

EN-50081-2
EN-50082-2



Digital Display: Red LED
Character Height: 18mm (0.7 inch).

Weight/Shipping Weight:

20 DO: 1.1 kg/1.6 kg
(2.5 lbs./3.5 lbs.).

1.4 ORDERING INFORMATION

The **Model 20-03 Dissolved Oxygen Microprocessor Transmitter** is housed in a NEMA 4X weatherproof, corrosion-resistant housing suitable for panel, pipe or wall mounting. The transmitter operates on 115 / 230 VAC, 60 Hz. Standard features include an LED digital display, continuous self diagnostics, isolated current output, dual alarms, and automatic temperature compensation.

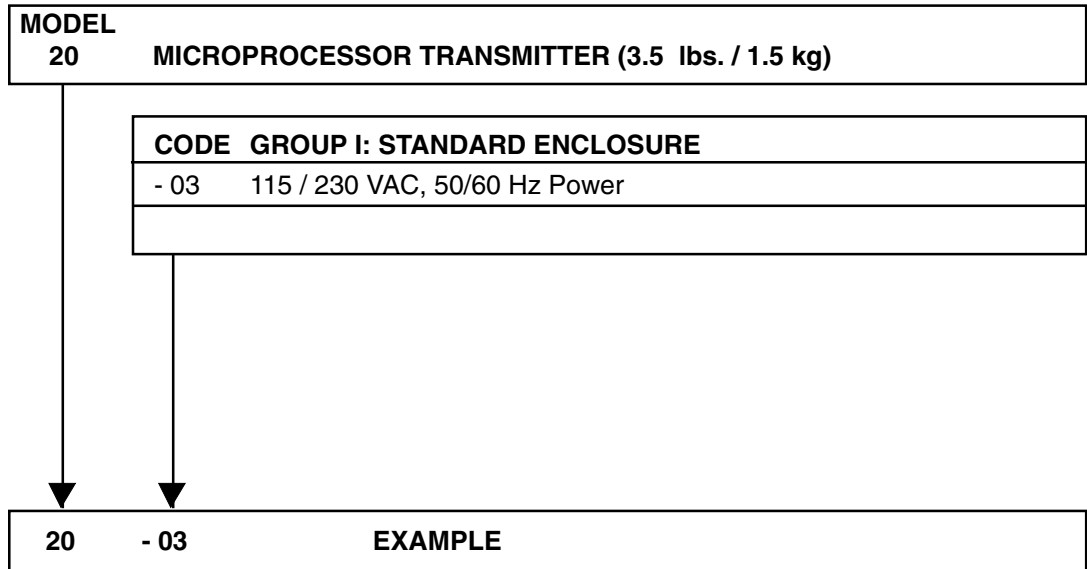

NOTE:

SELECT ONLY OXYPROBE® DISSOLVED OXYGEN SENSORS FOR USE WITH MODEL 20-03. Recommended cable from sensor to transmitter is BJC Type “D” or equivalent, available from factory as either P/N: AX-5000-D4-D03S5 (with exposed 4-pin connector), or AX-5100-D4-D03S5 (with Protective Cap for 4-pin connector). Suggested cable part numbers have cable length = 3 ft. (1M). Specify lengths greater than 3 feet (1M) in 1 foot increments up to 60 ft. (18 M) maximum length.

SECTION 2.0 INSTALLATION

2.1 UNPACKING AND INSPECTION. Before opening the shipping carton, inspect the outside of the carton for any damage. If damage is detected, contact the carrier immediately. Make sure all the items on the packing list are present and in good condition. Notify the factory if any part is missing. If the transmitter appears in satisfactory condition, proceed to Mechanical Installation.

NOTE

Save the original packing cartons and materials as most carriers require proof of damage due to mishandling, etc., also, if it is necessary to return the transmitter to the factory, you must pack the transmitter in the same manner as it was received. See Section 9 for return instructions.

2.2 MECHANICAL INSTALLATION.

IMPORTANT

Do not attempt to install and operate the MODEL 20-03 without first reading this manual.

This transmitter's enclosure is suitable for outdoor use. However it should be located in an area where temperature extremes, vibrations, electromagnetic and radio frequency interferences are minimized or absent. Select an installation site that is at least one foot from any high voltage conduit, has easy access for operating personnel, and is not in direct sunlight. Mount the MODEL 20-03 as follows:

1. Remove the four screws that secure the rear cover of the enclosure.
2. Follow the procedure for the appropriate mounting configuration: Section 2.2.1 for panel mounting, Section 2.2.2 for wall mounting or Section 2.2.3 for pipe mounting.

2.2.1 Panel Mounting (Standard). The MODEL 20-03 is designed to fit into a DIN standard 137.9 mm X 137.9 mm (5.43 inch X 5.43 inch) panel cutout (refer to Figures 2-1 and 2-2).

1. Prepare the transmitter as described in Section 2.2.
- 2a. (This step is not required for wall mounting configuration). Remove the four screws holding the front panel assembly of the enclosure and carefully pull the front panel and connected printed circuit boards straight out.
2. Install the mounting latches as shown in Figure 2-2. If the latches are not installed exactly as shown, they will not work correctly. The screws provided are self-tapping. Tap the screw the full depth of the mounting latch (refer to side view) leaving a gap greater than the thickness of the cutout panel.
3. Align the latches as shown and insert the transmitter enclosure through the front of the panel cutout. Tighten the screws for a firm fit. To avoid damaging the mounting latches, do not overtighten.
4. Replace the front panel assembly. Circuit boards must align with the slots on the inside of the enclosure. Replace the four front panel screws.

2.2.2 Wall Mounting (Optional). Refer to Figures 2-4 and 2-5.

1. Prepare the transmitter as described in Section 2.2.
2. Mount the junction box and bracket to the transmitter with the hardware provided. All wiring can be brought to the terminal strip prior to mounting the transmitter.
3. Place the metal stiffener on the inside of the transmitter and mount the two 1/2 inch conduit fittings using two each weather seals as shown. Mount NEMA 4X conduit plug (included) into center conduit hole.
4. Mount the transmitter to the junction box using the 1/2 inch conduit fittings.
5. Complete wiring from the transmitter to the junction box (see Figure 2-5).

2.2.3 Pipe Mounting (Optional). The 2" pipe mounting bracket includes a metal plate with a cutout for the transmitter (refer to Section 2.2 for mounting the transmitter into the plate). Mounting details are shown in Figure 2-6.

2.3 ELECTRICAL WIRING. The MODEL 20-03 has three conduit openings in the bottom rear of the transmitter housing which will accommodate 1/2 inch conduit fittings. From a back view, the conduit opening on the left is for timer, alarm, and AC power supply connections; the center is for signal output and the opening on the right is for sensor wiring.

Sensor wiring should always be run in a separate conduit from power wiring.

NOTE

For best EMI/RFI protection the output cable should be shielded and enclosed in an earth grounded rigid metal conduit. Connect the outer cable shield to earth ground terminal 8 of either TB2 or TB3 when wiring direct to the transmitter, Fig. 2-7.

The sensor cable should also be shielded. When wiring directly to the transmitter, connect the sensor cable's outer shield to the transmitter's earth ground via terminal 8 of TB2. If the sensor cable's outer shield is braid, an appropriate metal cable gland fitting may be used to connect the braid to earth ground via the transmitter case.

2.3.1 Power Input Wiring. The MODEL 20-03 can be configured for either 115 Vac or 230 Vac power.

Connect AC power to TB1-8 and -9 (115 VAC) or to TB1-7 and -8 (230 VAC). Connect ground to TB3-8 (refer to Figure 2-7).

CAUTION

The sensitivity and stability of the transmitter will be impaired if the input wiring is not grounded. DO NOT apply power to the transmitter until all electrical connections are verified and secure. The following precautions are a guide using UL 508 as a safeguard for personnel and property.

1. AC connections and grounding must be in compliance with UL 508 and/or local electrical codes.
2. The metal stiffener is required to provide support and proper electrical continuity between conduit fittings.
3. This type 4/4X enclosure requires a conduit hub or equivalent that provides a watertight connection, REF UL 508-26.10.
4. Watertight fittings/hubs that comply with the requirements of UL 514B are to be used.
5. Conduit hubs are to be connected to the conduit before the hub is connected to the enclosure, REF UL 508-26.10.
6. If the metal support plate is not used, plastic fittings must be used to prevent structural damage to the enclosure. Also, the appropriate grounding lug and AWG (American wire gage) conductor must be used with the plastic fittings.

2.3.2 Output Wiring. The alarm connections are made to terminals 1 through 4 of TB1 (refer to Figure 2-7). The current loop output connections are made to TB3-1(+) and TB3-2(-). Timer relay connections are made to TB1-5 and TB1-6.

NOTE

Install weathertight seal P/N AM-9263 in the unused opening.

2.3.3 Sensor. Refer to Figure 2-8 and the OxyProbe® sensor instruction manual P1431 for additional wiring instructions. DO NOT install the sensor in the process at this time.

2.4 EMC (ELECTROMAGNETIC COMPATIBILITY) INSTALLATION GUIDELINES. The CE mark affixed to an instrument is your guarantee of compliance with all applicable European directives when installed and operated correctly. Please refer to the following installation guidelines and recommended cable separations provided in FIGURE 2-9.

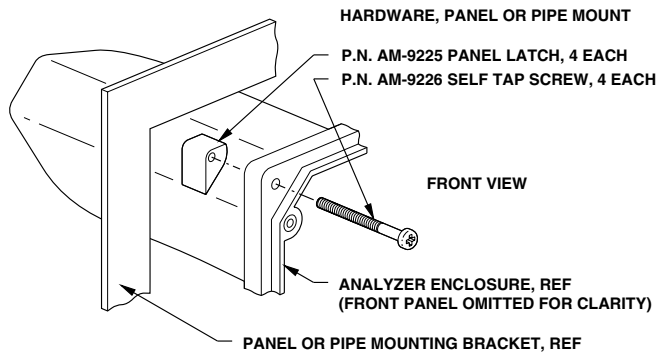
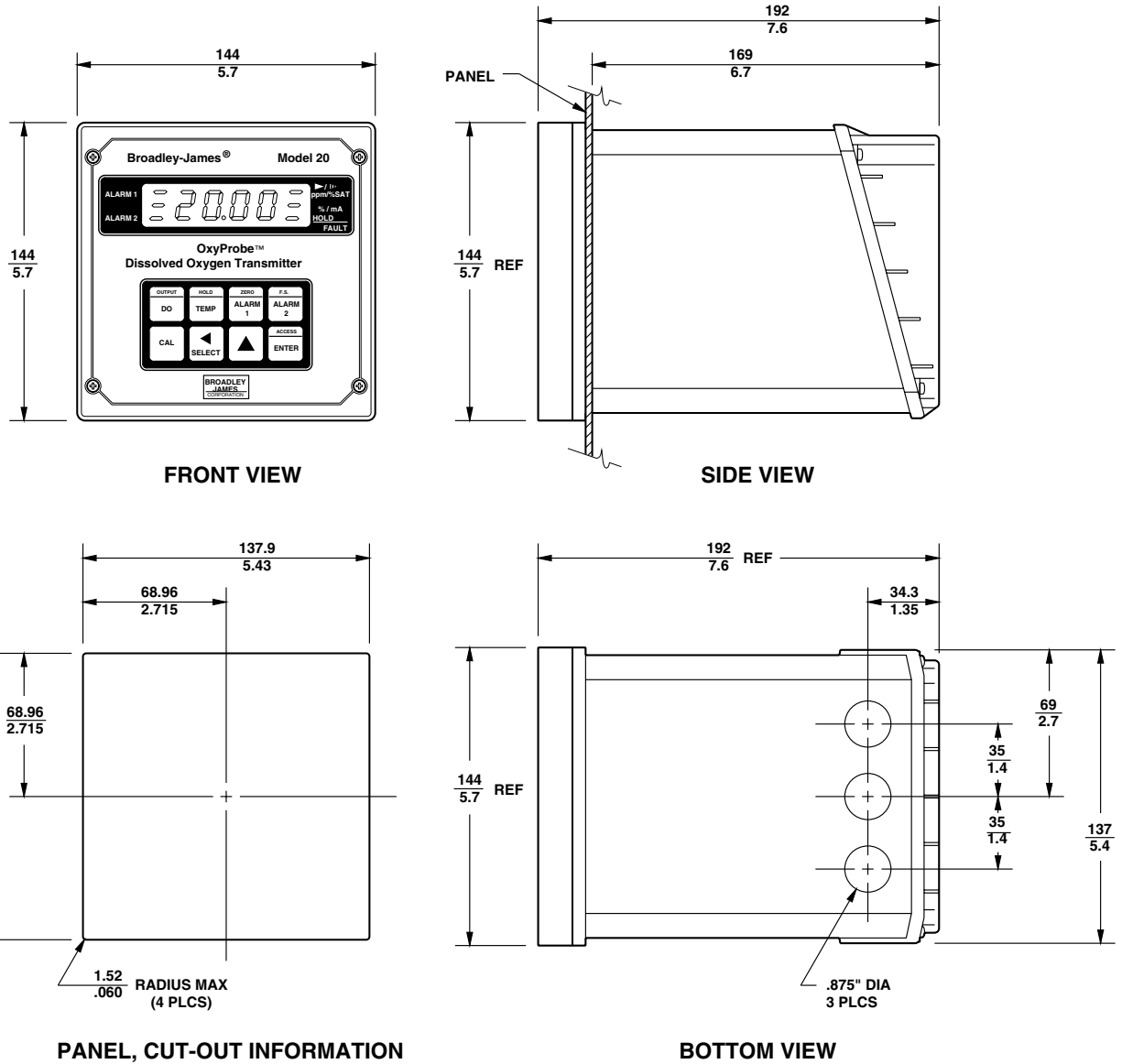

WHEN INCH AND METRIC DIMS ARE GIVEN

MILLIMETER INCH

FIGURE 2-1. Panel Mounting Cutout

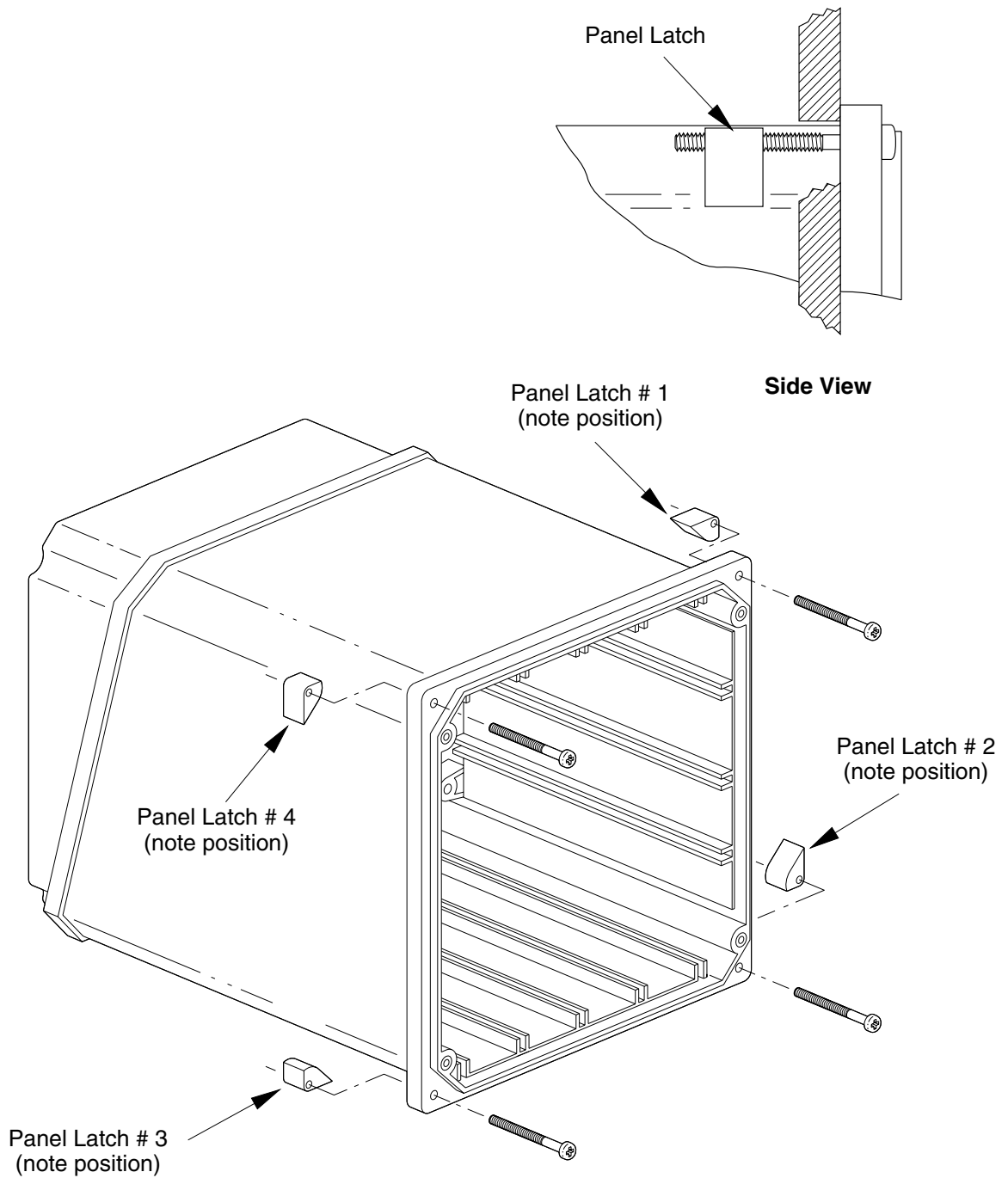
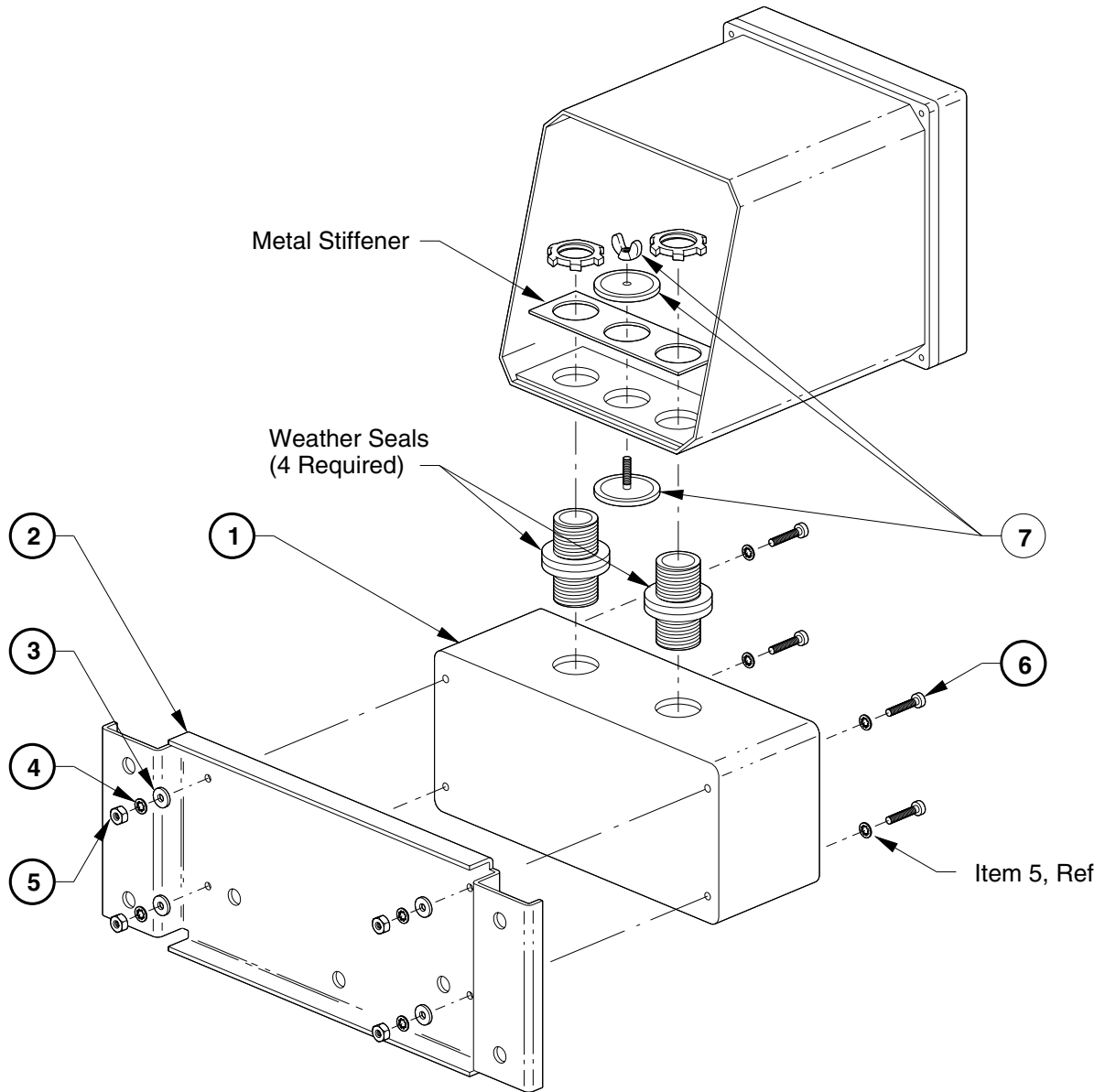

FIGURE 2-2 Panel Mounting Latch Installation



ITEM	PART NUMBER	DESCRIPTION	QTY
1	AM-9241	J-Box Sub-assembly	1
2	AM-9242	Wall Mounting Bracket	1
3	AM-9243	#6 Flat Washer	4
4	AM-9244	#6 Internal Lock Washer	4
5	AM-9245	6-32 Hex Nut	8
6	AM-9246	6-32 x .75 Screw	4
7	AM-9247	Weathertight Seal	1

FIGURE 2-4 Wall Mounting J-Box Installation

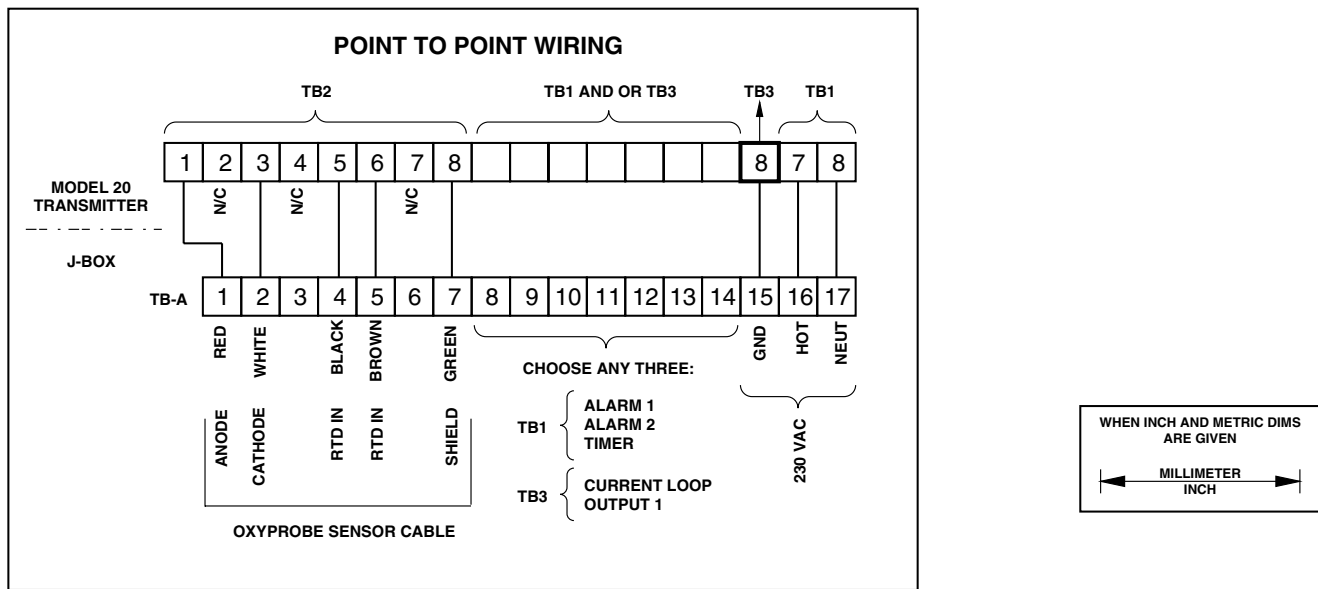
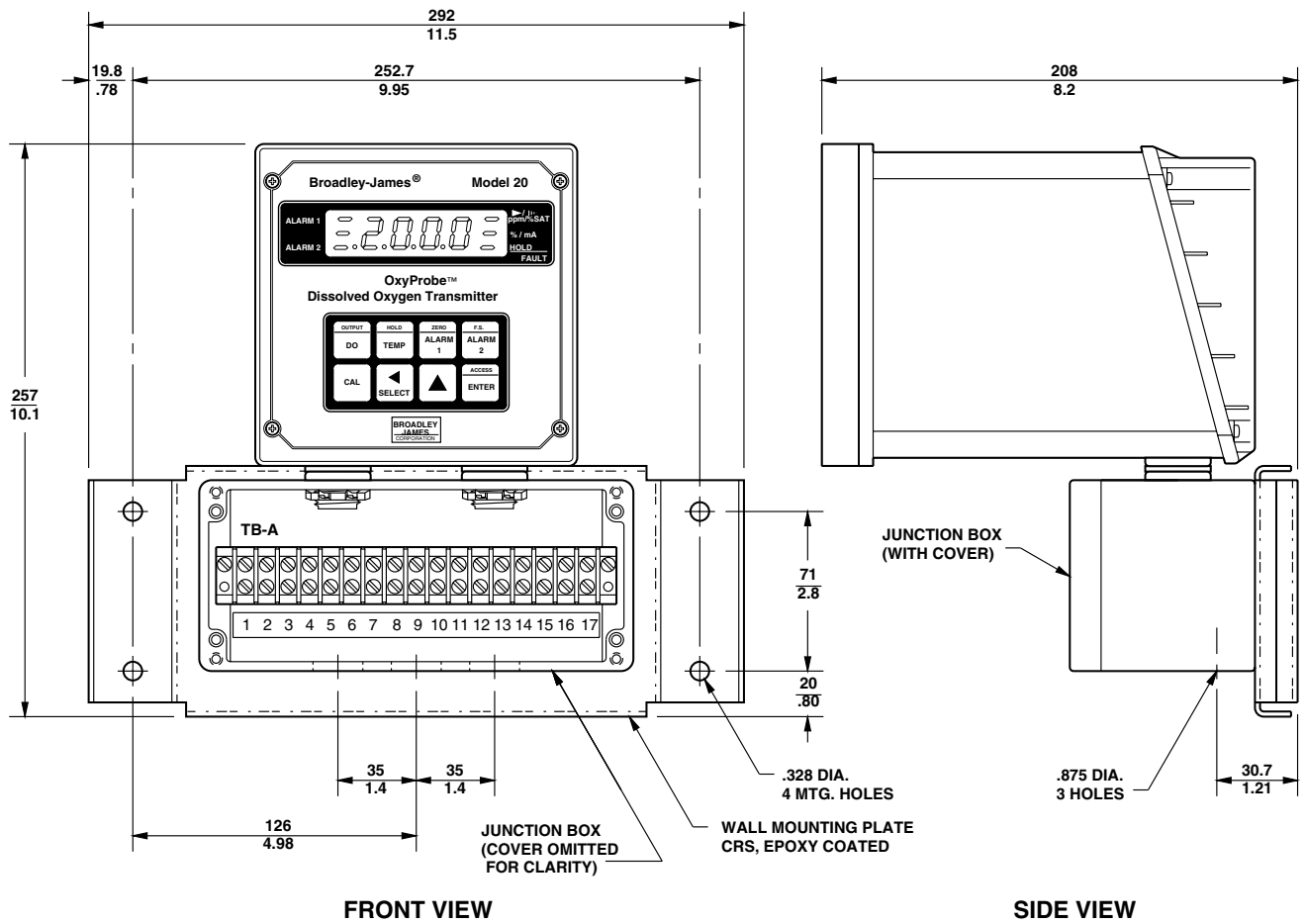

FIGURE 2-5. Wall Mounting J-Box Wiring

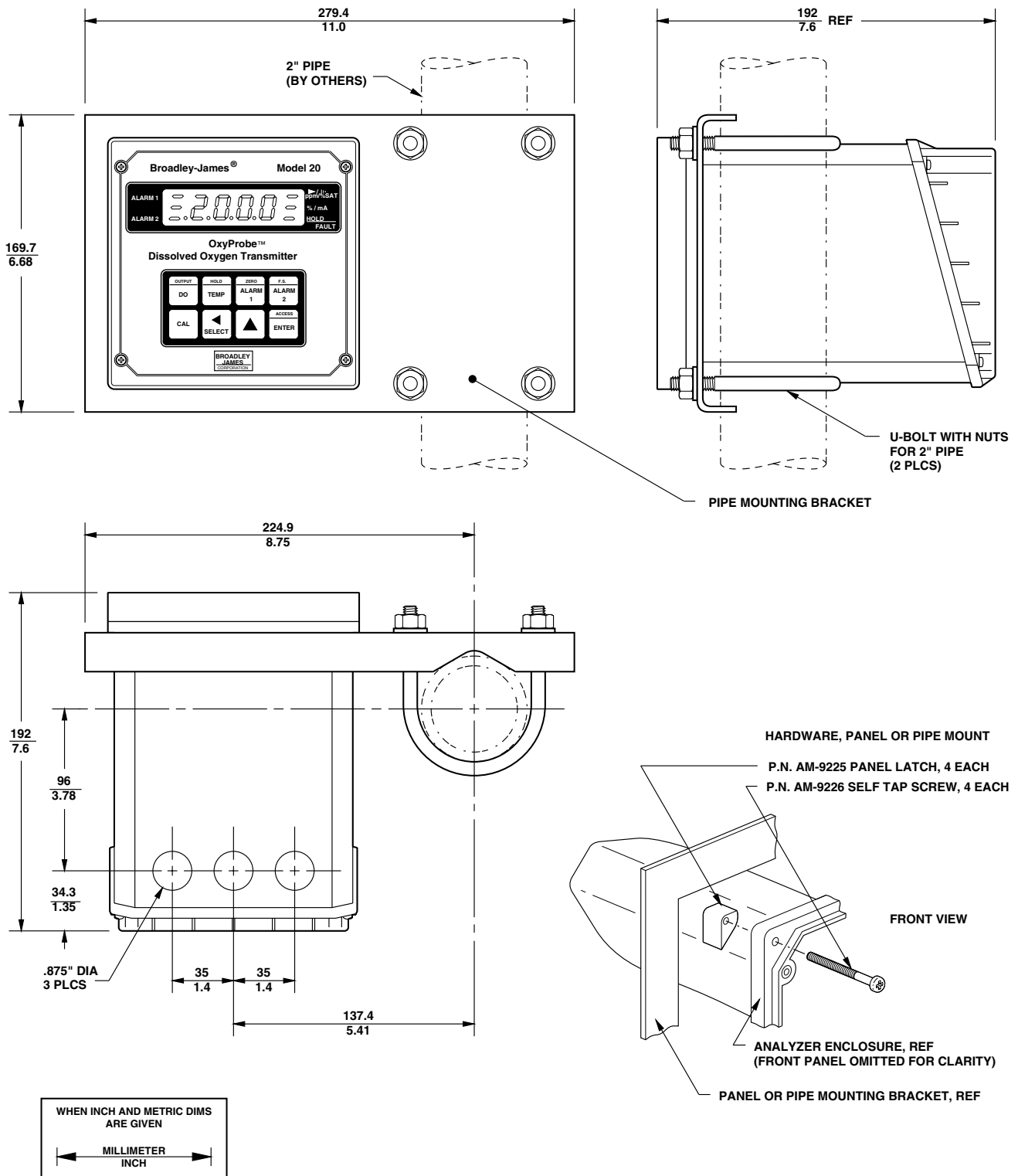
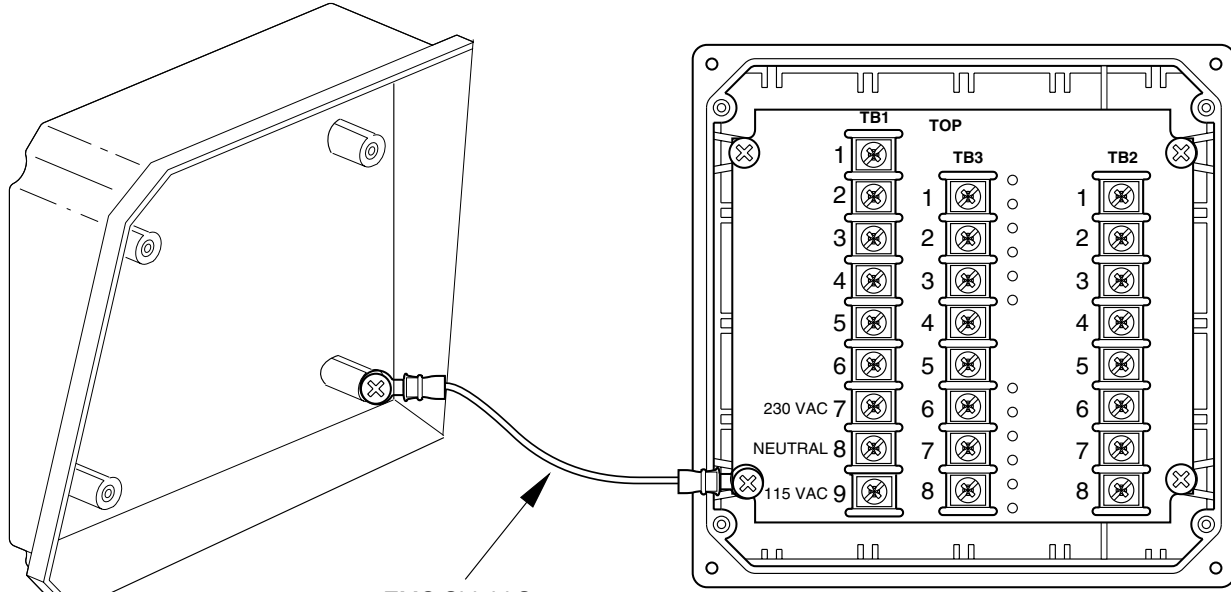
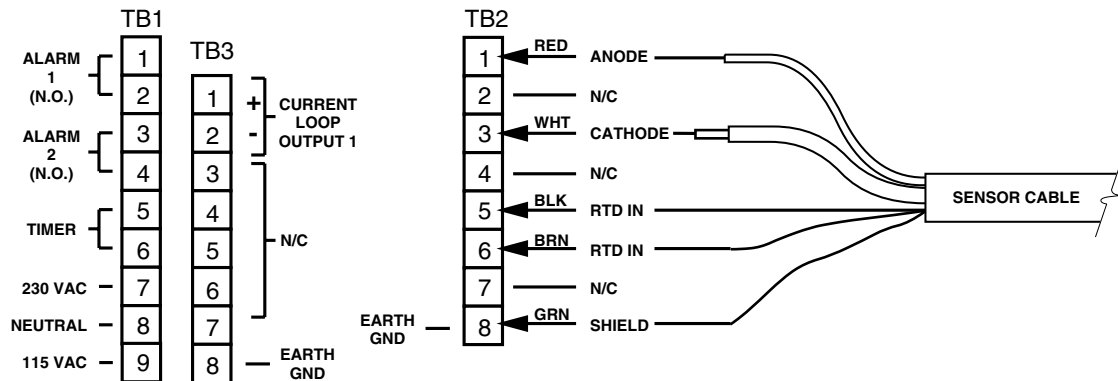

FIGURE 2-6. Pipe Mounting Installation



EMC Shield Strap
for Enclosure
(Must be connected to rear
cover and Mother Board as
shown for proper operation)

BACK VIEW /COVER OMITTED



FIELD TERMINAL BOARD CONNECTIONS

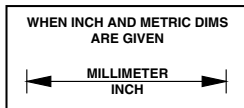
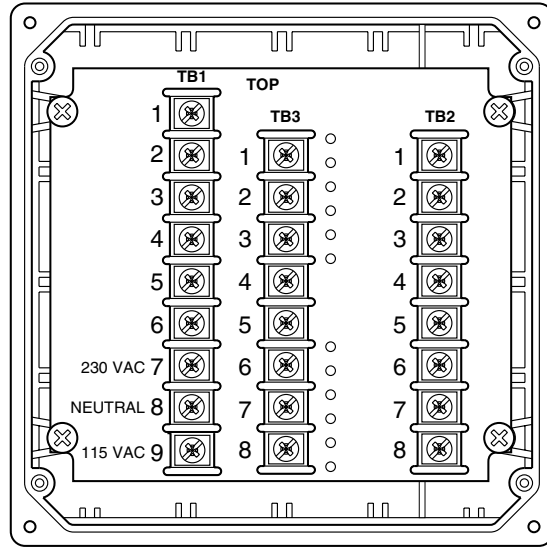

FIGURE 2-7. Model 20 - 03 DO Electrical Wiring



BACK VIEW /COVER OMITTED

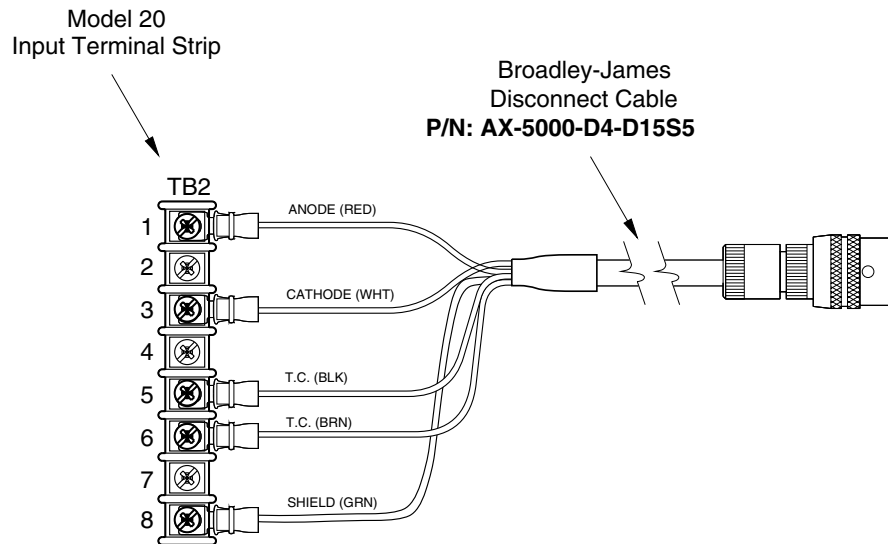

FIGURE 2-8. Model 20-03 DO Sensor Wiring

Signal Cable	Power Cable					
	Twin (round) PVC sheathed	Twin & Earth	Earthed conduit	Earthed trunking	Steel wire armoured	MICC
Twin (flat) PVC sheathed	160	145	145	120	105	15
Aluminum foil screened	105	80	30	35	25	15
Twin (round) PVC sheathed	65	90	35	25	20	15
Unscreened twisted pair	60	65	25	25	15	15
Coaxial	20	20	20	15	20	15
Screened twisted pair	15	20	15	15	15	15
Steel wire armoured	15	15	15	15	15	15
MICC	15	15	15	15	15	15

Minimum Cable separation distances in millimeters based on 100 meter parallel cable run and with up to 125 amps flowing in power cable.

FIGURE 2-9. Recommended Minimum Cable Separation Guidelines

2.4.1 Screening & Earthing. Screen (i.e. shield) integrity must be maintained throughout. If cable is broken for any reason, a screened enclosure correctly terminated must be used with no effective RF apertures. Signal and logic I/O cable screens must only be terminated at one end, preferably at the instrument.

Rigidly employ a star point earthing policy for individual instruments and systems. Do not link earth connections in a daisy chain. Use wide straps or braids for earth connections, as wire exhibits significant inductance and therefore high impedance to RFI. All instruments which have a protective earth terminal must have a sound true earth connection to that terminal.

When completed the screen bonding and earth continuity should be checked with an ohm-meter.

2.4.2 Summary of EMC Guidelines.

- Keep sensor and signal cables as short as possible.
- Do not bundle with electrically noisy cables. Use the recommended separation distances.
- Always use the recommended cables.
- Ensure that the screen integrity is maintained throughout the whole installation.
- Fit suppression devices to contactor coils and other inductive loads such as solenoid valves.
- Ensure a good earth is available and connect all earths separately in star point.

SECTION 3.0 DESCRIPTION OF CONTROLS

3.1 KEYBOARD FUNCTIONS. All functions of the Model 20-03 are accessed through keyboard entry routines. The transmitter uses no switches or potentiometers.

The four keys across the top row and the **ENTER** keys are dual function. One press of the key will display the value of the function shown on the lower portion of the key. A quick double press of the key will display the value of the function shown on the upper portion of the key. Each of these keys have read functions that can be accessed without security code entry. Each key also has a calibration or set function when used with the **SELECT** key. This function requires entry of the security code when the security feature is active. (Refer to Section 6.0 for keyboard security.)

NOTE

When no key is pressed for a period of 60 seconds the transmitter will default to reading DO.

CAUTION

The **HOLD** function and the **CAL** function are not read functions. Refer to section 5.3.

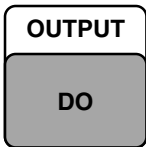

A. Standardize DO. Standardization of the DO sensor is achieved by pressing the **DO** key once, followed immediately by pressing the **SELECT** key. “Std” displays to acknowledge the standardize function, followed by the Numeric Display for user input. Entering the known DO value of the measured solution will cause the transmitter to restandardize the sensor. Refer to Section 5.3.

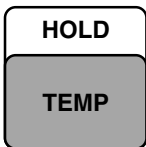

B. Standardize Temperature. Standardization of the temperature is achieved by pressing the **TEMP** key once, followed immediately by pressing the **SELECT** key. “AdJ” displays to acknowledge the standardization function, followed by the Numeric Display for user input. Entering the known temperature of the measured solution will cause the

transmitter to restandardize the temperature reading. Refer to Section 5.3.

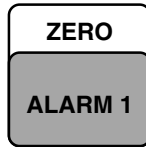

C. Alarm 1 and Alarm 2 Setpoint. The alarm setpoint may be adjusted by pressing the **ALARM 1** or **Alarm 2** key once, followed by pressing the **SELECT** key. “AdJ” displays, followed by the Numeric Display for user input. Refer to Section 4.2.

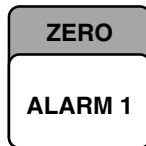

D. Current Output – Zero Setpoint. The zero point (0 or 4 mA) of the DO output range is adjusted by pressing the **ZERO** key twice, followed by pressing the **SELECT** key. “AdJ” displays, followed by the Numeric Display for user input. Refer to Section 4.14.

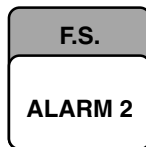

E. Current Output – F.S. Setpoint. The full scale point (20 mA) of the DO output range is adjusted by pressing the **F.S.** key twice, followed by pressing the **SELECT** key. “AdJ” displays, followed by the Numeric Display for user input. Refer to Section 4.14.



F. Calibration. ppm and % Saturation calibration is initiated by pressing the **CAL** key once. Refer to Sections 5.3.3 and 5.3.4 respectively.

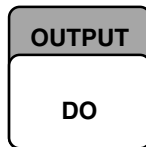

G. Simulate Current Output. The DO output can be simulated by pressing the **OUTPUT** key twice, followed by pressing the **SELECT** key. The Numeric Display appears for user input. Refer to Section 4.15.

3.1.1 Item Selection and Value Adjustment Keys.

The three keys located on the lower right side of the keypad are used for menu navigation, value adjustment and entry, and item selection. These keys perform the following functions:



A. SELECT/Shift (◀) Key. This key is used to select the displayed menu, or for shifting to the next digit in the Numeric Display.

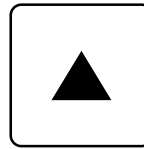

B. Scroll Key (▲). This key is used to scroll through menu when selected, or scroll through digits on the active (flashing) Numeric Display. Holding key down auto scrolls through the main menu and Numeric display.



C. ACCESS/ENTER Key. This key is used to **ACCESS** the Set Mode (Section 4.1.1) and to **ENTER** the displayed value into memory (from Numeric Display).

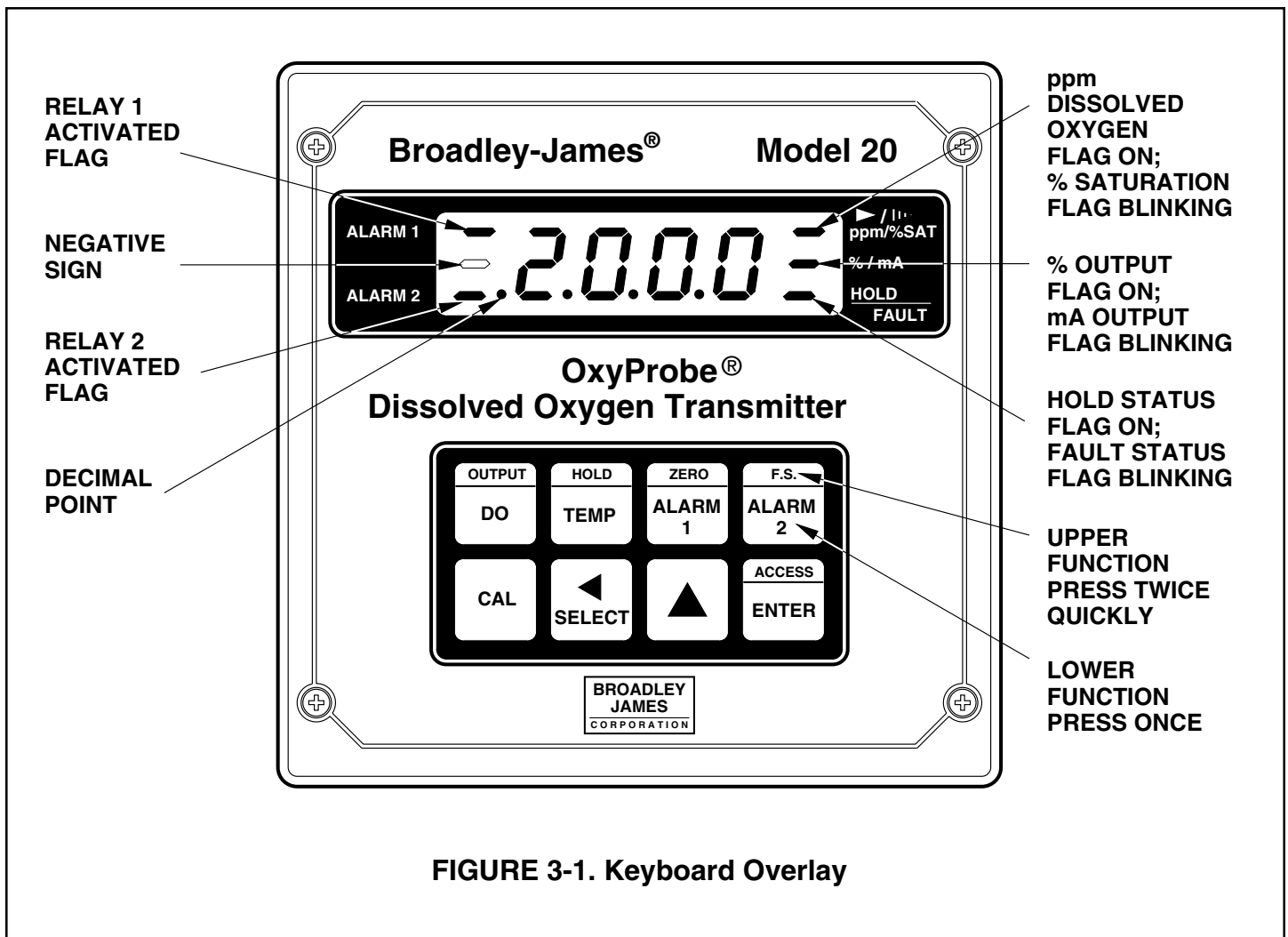

FIGURE 3-1. Keyboard Overlay

Table 3-1. Key Description



	MAIN FUNCTION (PRESS ONCE)	SECOND FUNCTION (PRESS TWICE QUICKLY)
<div style="border: 1px solid black; padding: 2px; width: fit-content; margin-bottom: 5px;">OUTPUT</div> <div style="border: 1px solid black; padding: 2px; width: fit-content; margin-bottom: 5px;">DO</div>	<p>Displays - DO in ppm or % Saturation.</p> <p>Set Function [w/SELECT(◀)] - One point standardization of DO. (Removes transmitter from Set Mode)</p>	<p>Displays - current output (mA or % full scale).</p> <p>Set Function [w/SELECT(◀)] - Simulates current output.</p>
<div style="border: 1px solid black; padding: 2px; width: fit-content; margin-bottom: 5px;">HOLD</div> <div style="border: 1px solid black; padding: 2px; width: fit-content; margin-bottom: 5px;">TEMP</div>	<p>Displays - process temperature (°C or °F).</p> <p>Set Function [w/SELECT(◀)] - One point standardization of temperature.</p>	<p>Initiates or removes transmitter from hold condition.</p>
<div style="border: 1px solid black; padding: 2px; width: fit-content; margin-bottom: 5px;">ZERO</div> <div style="border: 1px solid black; padding: 2px; width: fit-content; margin-bottom: 5px;">ALARM 1</div>	<p>Displays - Alarm 1 setpoint.</p> <p>Set Function [w/SELECT(◀)] - Sets Alarm 1 setpoint.</p>	<p>Displays - low "Lo" current setpoint (0 or 4 mA value); the low end of the dissolved oxygen range that corresponds to) or 4 mA DC output.</p>
<div style="border: 1px solid black; padding: 2px; width: fit-content; margin-bottom: 5px;">F.S.</div> <div style="border: 1px solid black; padding: 2px; width: fit-content; margin-bottom: 5px;">ALARM 2</div>	<p>Displays - Alarm 2 setpoint.</p> <p>Set Function [w/SELECT(◀)] - Sets Alarm 1 setpoint.</p>	<p>Displays - full "Hi" scale output setpoint; the high end of the dissolved oxygen range that corresponds to 20 mA DC output.</p>
<div style="border: 1px solid black; padding: 2px; width: fit-content; margin-bottom: 5px;">CAL</div>	<p>Displays - Barometric pressure setting. Used to calibrate transmitter and the dissolved oxygen sensor loop in air. Set Function [w/ SELECT(◀)] - One point standardization of % Saturation.</p>	<p style="text-align: center;">CAUTION</p> <p>air calibrate only when the sensor is fully polarized and stabilized in ambient air.</p>
<div style="border: 1px solid black; padding: 2px; width: fit-content; margin-bottom: 5px;"> SELECT</div> <div style="border: 1px solid black; padding: 2px; width: fit-content; margin-bottom: 5px;"> ACCESS</div> <div style="border: 1px solid black; padding: 2px; width: fit-content; margin-bottom: 5px;">ENTER</div>	<p>Select sub menu (mnemonic display). Shift to next digit (numeric display). Activate decimal point adjustment.</p> <p>Scroll through menu (mnemonic display). Scroll digits (numeric display). Holding key down autoscrolls digits or set menu items.</p> <p>Press twice quickly to access set-up menu. Enter displayed value into memory. Enter displayed menu item (flashing) into memory.</p>	<p style="text-align: center;">NOTE</p> <p>When no key is pressed for a period of 60 seconds the transmitter default to reading DO.</p> <p style="text-align: center;">CAUTION</p> <p>The HOLD function and the CAL function are not read functions. Refer to Sections 4.16 and 5.0 respectively.</p>

TABLE 3-2. Information Mnemonics

MNEMONIC	DESCRIPTION	MNEMONIC	DESCRIPTION
RdJ	Adjustment to value reading	SEt	Set mode
bRd	Incorrect entry	Si C	Simulates current output (mA)
Hl	Displays 20 mA setpoint (pH)	SEP	Simulates current output (percent)
i tr	Interval timer activated	SP 1	Displays alarm 1 setpoint
L0	Displays 0 or 4 mA setpoint (pH)	SP2	Displays alarm 2 setpoint
L0C	Access locked - enter security code	Std	Standardize DO

TABLE 3-3. Set Function Mnemonics

RL 1	Alarm 1 setup	dPn	Dampen output	on	Function on
RL 2	Alarm 2 setup	dt5	LED Display test	OFFt	Off time duration
RLc	Automatic temp. comp.	dur	Waiting period duration	OUT	Current output
br	Barometric reset	°F	Temperature °F	Pct	Display output in percent
bP	Barometric pressure	FLt	Fault alarm set	PPu	Parts per million
°C	Temperature °C	Hl	Relay action - high	rL 1	Relay 1 fault setup
COd	Security Code	H-L	Alarm logic	rL 2	Relay 2 fault setup
cnt	Count on times	hr	Hours	SRt	% Saturation
CUr	Config. mA output display	HYS	Hysteresis	SEt	Seconds
Cur	Config. fault output	i H	Inches mercury	SHD	Show fault history
cur	Default current setpoint	i n	Display sensor input (nA)	SoL	Solubility correction
dRd	Days	i nt	Interval period	t-C	Temperature config.
dFt	Fault Configuration	i nt	Timer setup	t, L	Timer - time remaining
do	Dissolved oxygen	Lo	Relay action - low	tOn	Timer status
d-O	Display output	non	No action on fault	UER	Display user version number
d-t	Display temperature	OFF	Alarm off	un	Minutes
doC	Display output in mA	off	Function off	420	4mA to 20mA output
doF	Relay delay off time	ont	On time duration	020	0mA to 20mA output
don	Relay delay on time	On	Alarm on	-0-	Transmitter zero

NOTE: See Table 8-1. for Fault Mnemonics

3.2 KEYBOARD ROUTINE. To familiarize yourself with the keyboard operation, practice on the following routines. Refer to Figure 3-1 and Table 3-1.

REMINDER

Press once to access the lower function shown on the key. Press twice quickly to access the upper function shown on the key.

3.2.1 Read Only Function.

1. Press the **DO** key to display the present process dissolved oxygen or percent saturation value. "dO" or "SRt" will appear briefly, then the DO or percent saturation value is displayed.
2. Press the **TEMP** key to display the present process temperature. "oF" or "oC" will appear briefly, then the temperature is displayed.
3. Press the **ALARM 1** key to display the Alarm 1 setpoint. "SP 1" will appear briefly, then the Alarm 1 setpoint is displayed.
4. Press the **ALARM 2** key to display the Alarm 2 setpoint. "SP 2" will appear briefly, then the Alarm 2 setpoint is displayed.
5. Press the **ZERO** key twice to display the low point of the dissolved oxygen output range that corresponds to 0 or 4 mADC output. "L 0" will appear briefly, then the low point is displayed.
6. Press the **F.S.** key twice to display the full scale (high) point of the dissolved oxygen output range that corresponds to 20 mADC output. "Hi" will appear briefly, then the full scale point is displayed.
7. Press the **OUTPUT** key twice to display the signal output in milliamps or percent. "dO c" or "Pct" will appear briefly, then the output is displayed. A steady flag indicates % while a blinking flag indicates mA.

3.2.2 Set Functions. Refer to Figure 4-1, Set Function Menu. This guide will assist in navigating through the various functions in the set menu.

1. Press the **ACCESS** key twice. "SEt" appears briefly, then the first set function, "br", is displayed

2. Scroll down through the first level of functions vertically from "br" by repeatedly pressing the **SCROLL (▲)** key to "L 0". Press **SCROLL (▲)** again to go back to "RL 1".
3. Now use the **SELECT (◀)** and **SCROLL (▲)** keys to reach the last sublevel function, vertically and to the left, for each of the first level functions. Follow the diagram shown in Figure 4-1, Set Function Menu.

3.2.3 Entering Numerical Values. After successfully reaching all the functions in the set menu, practice entering numerical values.

1. Press the **DO** key to get out of the Set Mode, then press the **ALARM 1** key.
2. Press the **SELECT (◀)** key. "RL 1" appears briefly then the Alarm 1 setpoint is displayed with the right digit flashing, prompting the user to change the value.
3. Press the **SCROLL (▲)** key to change the flashing digit.
4. When the desired digit is displayed, shift to the next digit on the left by pressing the **SELECT (◀)** key. This digit will now start flashing.
5. Repeat Steps 3 and 4 until you reach the fourth digit. This digit can only be set to a "1", "2", or a blank (̄), by using the **SCROLL (▲)** key.
6. Press the **SELECT (◀)** key to activate the decimal point adjust. (If the decimal point is not displayed, it must be to the right of the first digit.) Press the **SCROLL (▲)** key again and it will move to the left of the first digit.
7. Press the **SCROLL (▲)** key to shift the decimal point one place to the left until the desired location is reached.
8. Press the **ENTER** key to put the value into memory.
9. Proceed to Section 4.0 Configuration.

NOTES

SECTION 4.0 CONFIGURATION

4.1 GENERAL. This section details all of the items available in the Set Mode and the setpoint adjustment procedures to configure the MODEL 20-03 Dissolved Oxygen Transmitter. Refer to Table 3-3 and Figure 4-1.

4.1.1 Set Mode “SET”. Most of the transmitter’s configuration is done while in the Set Mode. Please refer to Figure 4-1 for the layout of all menu items. All menu variables are written to the transmitter’s EEPROM (memory) when selected and remain there until changed. As these variables remain in memory even after the transmitter’s power is removed, the transmitter configuration may be performed prior to installing it.

1. Make sure the transmitter loop is properly wired. Power up the transmitter. Only power input wiring is required for transmitter configuration. (Refer to Section 5.2 regarding polarization voltage.) The transmitter’s display will begin showing values and/or fault mnemonics. All fault mnemonics will be suppressed while the transmitter is in Set Mode (the fault flag will continue to blink).
2. Enter Set Mode. Pressing the **ACCESS** key twice will place the transmitter in Set Mode. The display will show “SET” to confirm that it is in Set Mode. It will then display the first item in the set menu “br”. The transmitter is now ready for user configuration.

NOTE:

If “LOC” displays, the Keyboard Security Code must be entered to access the Set Mode. (Refer to Section 6.0.) To get out of the Set Mode, press the **DO** key. Refer to the Configuration Worksheet on page 19 for the transmitter ranges and factory settings.

4.1.2 Configuration Work Sheet. The Configuration Worksheet provides the range of the various functions, the factory settings, and a column for user’s settings. As you proceed through the configuration procedures for each function of the transmitter, fill in the appropriate information in the “USER” column. The configuration may be done in any order. However, it is recommended that it be done in the order as shown in the worksheet.

4.1.3 Barometric Pressure. Display Mnemonic “br”. This function is used to update the barometric pressure setting after the transmitter/sensor loop has been air calibrated and the sensor installed in the process. Refer to Section 5.0 Start-up Calibration. It is only used for the % SAT mode.

4.1.4 Transmitter Zero. Display Mnemonic “-0-”. This function is used to zero the transmitter/sensor loop. Refer to Section 5.3.2 Start-up and Calibration.

4.1.5 Sensor Input. Display Mnemonic “i n”. This function is used to display current input from the sensor. Refer to Section 8.2.4 Sensor Troubleshooting for more information.

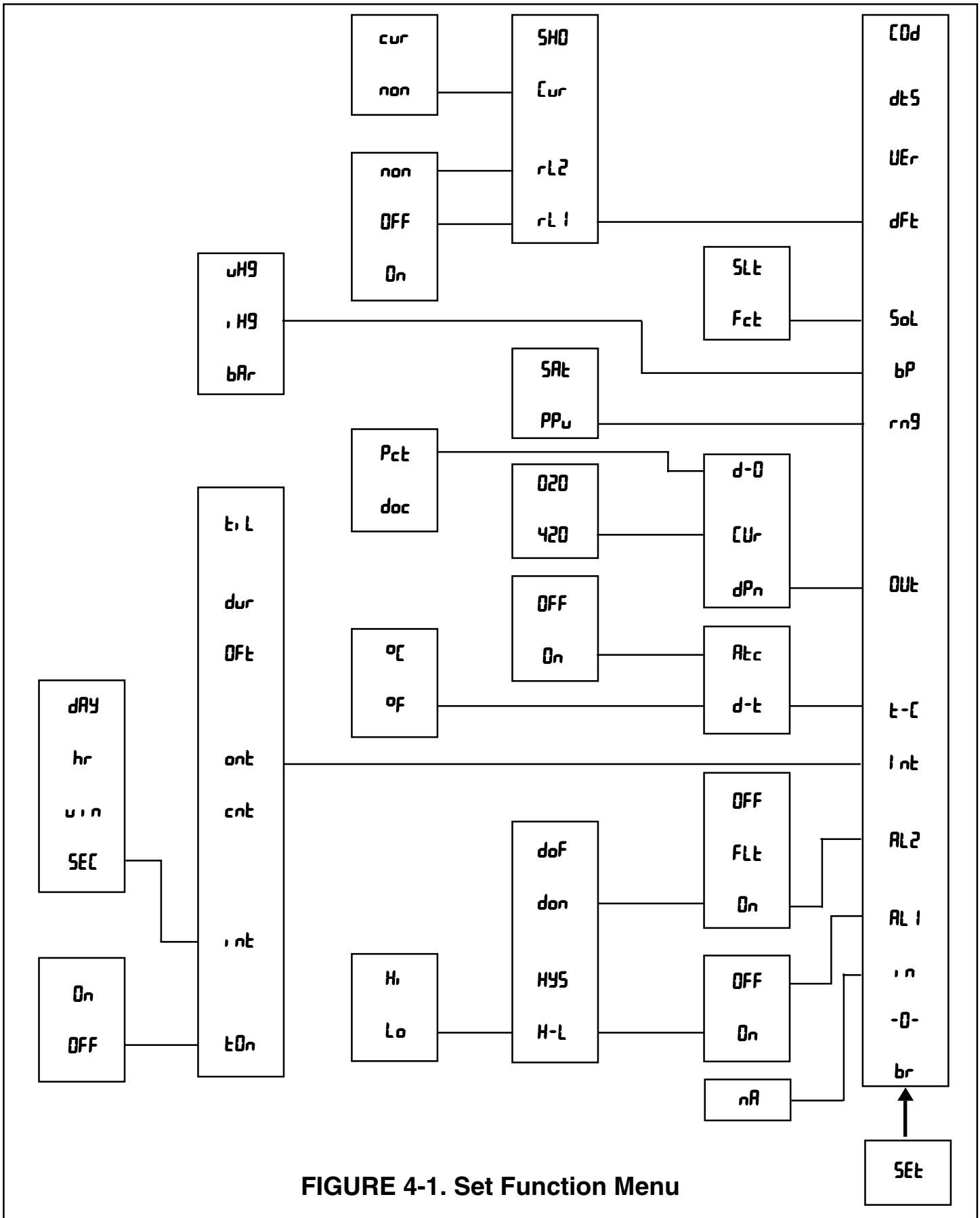

FIGURE 4-1. Set Function Menu

TABLE 4-1. Configuration Work Sheet

Use this work sheet to assist in the configuration of the transmitter.

Date: _____

	RANGE	FACTORY SET	USER SET
A. Alarm 1 Setup (AL 1)			
1. Alarm Status (On/Off)		On	_____
2. High or Low (H-L) (Hi/Lo)		Lo	_____
3. Hysteresis (HYS)	0-25%	0.00%	_____
4. Delay Time On (don)	0-255 sec.	000 Seconds	_____
5. Delay Time Off (doF)	0-255 sec.	000 Seconds	_____
B. Alarm 2 Setup (AL 2)			
1. Alarm Status (On/FLt/Off)		On	_____
2. High or Low (H-L) (Hi/Lo)		Hi	_____
3. Hysteresis (HYS)	0-25%	0.00%	_____
4. Delay Time On (don)	0-255 sec	000 Seconds	_____
5. Delay Time Off (doF)	0-255 sec	000 Seconds	_____
C. Interval Timer (Int)			
1. Active Status (tOn) (off/on)		off	_____
2. Interval Time (int)	10 min. to 2,999 days	1 Day	_____
3. Count (cnt)	1 to 60	5	_____
4. On Time (ont)	0.1 to 299 sec	1 Second	_____
5. Off Time (offt)	0.1 to 299 sec	1 Second	_____
6. Duration (dur)	0.1 to 299 sec	2 Seconds	_____
D. Temperature Setup (t-C)			
1. Display Temperature (d-t) (°C/°F)		°C	_____
2. Automatic Temp Comp (Rtc) (on/off)		on	_____
a. Manual Temp. Value	0°C to 80°C		_____
E. Current Output Setup (Out)			
1. mA Output (Cur) (20/420)		420	_____
2. Display Current Output (d-0) (Pct/doc)		doc	_____
3. Dampen Current Output (dPn)	0-255 sec.	0.0 Seconds	_____
F. Output Range Setup (rng)			
1. Parts Per Million (PPM)	0-20	PPM	_____
2. Percent Saturation (SRt)	20-250%		_____
G. Barometric Pressure Setup (bP)			
1. Millimeters Mercury (uHg)	500-1000	uHg	_____
2. Inches Mercury (iHg)	19.67-39.37		_____
3. Bars (bAr)	0.666-1.333		_____
H. Solubility Correction Factor Setup (Sol)			
1. Solubility Constant (Sol)	0.09 - 9.00	1.00	_____
2. Solubility Factor for Saline Solutions (S ft)	0.00 - 2.00	0.00	_____
I. Default Setup (dft)			
1. Relay 1 Default (r1 i) (non/off/on)		non	_____
2. Relay 2 Default (r2 i) (non/off/on)		non	_____
3. Current Output Default (Cur) (non/cur)		non	_____
4. Current Output Held		non	_____
J. Keyboard Security Setup (Kd)			
1. Keyboard Security Required	001-999		_____
2. Keyboard Security Not Required	000	000	_____
Alarm Setpoints			
1. Alarm 1 (SP 1)	0-20 ppm	0 ppm	_____
2. Alarm 2 (SP 2)	0-20 ppm	20 ppm	_____
Current Output			
1. Zero (0 or 4 A) (L0)	0-20 ppm	0 ppm	_____
2. F.S. (20 A) (Hi)	0-20 ppm	20 ppm	_____

4.2 Alarm 1 and 2. Display Mnemonic “RL 1” or “RL 2”. Used to set alarm relay logic (See note below). Each alarm is configured separately. Choices are (see note below):

A. On. Display Mnemonic “ON”. Select this item if Alarm 1 or 2 is to be used. If “ON” is selected, “RL 1” or “RL 2” may be configured for either high (Hi) or low (Lo) alarm.

B. Off. Display Mnemonic “OFF”. Select this item if Alarm 1 or 2 will not be used or to temporarily disable the alarm. Alarm 1 or 2 setpoint will display “OFF” if this item is selected. All other Alarm 1 or 2 settings are ignored.

C. Fault. (In addition to “ON” and “OFF”, Alarm 2 may be configured to a fault alarm.) Display Mnemonic “FLT”. Select this item to make Alarm 2 a fault alarm. Relay 2 will energize when the transmitter experiences a fault condition. Alarm 2 setpoint will display “FLT” if this item is selected. All other Alarm 2 settings are ignored.

D. Alarm Logic. Display Mnemonic “H-L”. Select this item for high or low alarm logic. High alarm logic activates the alarm when the reading is greater than the setpoint value. Low alarm logic activates the alarm when the reading is less than the setpoint value.

E. Relay Hysteresis. Display Mnemonic “HY5”. Sets the relay hysteresis (dead band) for deactivation after reading has passed the alarm setpoint. May be set from 0 to 25% (of setpoint). Hysteresis is used to delay the alarm relay deactivation on the low side of the high alarm setpoint, or on the high side of the low alarm setpoint. This feature is used to prevent or minimize alarm chattering.

Examples.

1. High alarm hysteresis setpoint is 5%. High alarm setpoint is 100% Saturation. At high alarm conditions (process DO > 100% saturation), the high alarm relay will remain activated until the process DO drops to 95% saturation ($100 - (0.05 \times 100)$).

2. Low alarm hysteresis setpoint is 10%. Low alarm setpoint is 60% saturation. At low alarm conditions (process DO < 60% saturation) the low alarm relay will remain activated until the process DO rises to 66% saturation ($60 + (0.1 \times 60)$).

F. Delay Time On. Display Mnemonic “don”. Sets time delay for relay activation after alarm setpoint is reached. May be set from 0 to 255 seconds. Normal (no alarm)

state restarts time from zero. Use when a fixed time should pass before relay activation occurs.

G. Delay Time Off. Display Mnemonic “doF”. Sets time delay for relay deactivation after alarm setpoint is reached. May be set from 0 to 255 seconds. Alarm state restarts time from zero. Use when a fixed time should pass before relay deactivation occurs.

NOTE

Alarm logic may be changed from normally open (N.O.) to normally closed (N.C.) by cutting the bowties on the power supply PCB and adding a jumper between W4 & W5, and or W6 & W7, and or W8 & W9.

4.2.1 Alarm Setup (RL 1/RL 2). Refer to Figure 4-2 and Table 4-1.

1. Enter Set Mode by pressing the **ACCESS** key twice.
2. **SCROLL** (▲) until “RL 1” or “RL 2” appears on the display.
3. **SELECT** (◀) to move to the next menu level. “ON”, “OFF” or “FLT” (RL 2 only) will display.
4. **SCROLL** (▲) to display desired item then **SELECT** (◀).
5. If “OFF” is selected, display will show “OFF” to acknowledge. Press the **ENTER** key to return to “RL 1” or “RL 2”, concluding routine. If “ON” is selected, display will show “ON” to acknowledge, then display “H-L”. Proceed to Step 6. If “FLT” is selected (RL 2 only), display will show “FLT” to acknowledge. Press the **ENTER** key to return to “RL 2”.
6. **SELECT** (◀) “ON”, “H” or “LO” will display (flashing).
7. **SCROLL** (▲) to the desired item and **ENTER** it into memory. Display will return to “H-L”. If changes to relay activation logic are desired, proceed to Step 8, otherwise Step 12.
8. **SCROLL** (▲) to display “HY5”, “don” or “doF” then **SELECT** (◀). Numerical display will flash to indicate that a value is required.
9. Use the **SCROLL** (▲) and **SELECT** (◀) keys to display the desired value.
10. **ENTER** the value into memory. Transmitter will acknowledge and return to display of last item selected. Repeat Step 8 if further changes are desired, otherwise Step 12.
11. Repeat Step 3 for the other Alarm’s settings as required.
12. Press the **ENTER** key to return to the first level of the Set Menu, or press the **DO** key to get out of the Set Mode.

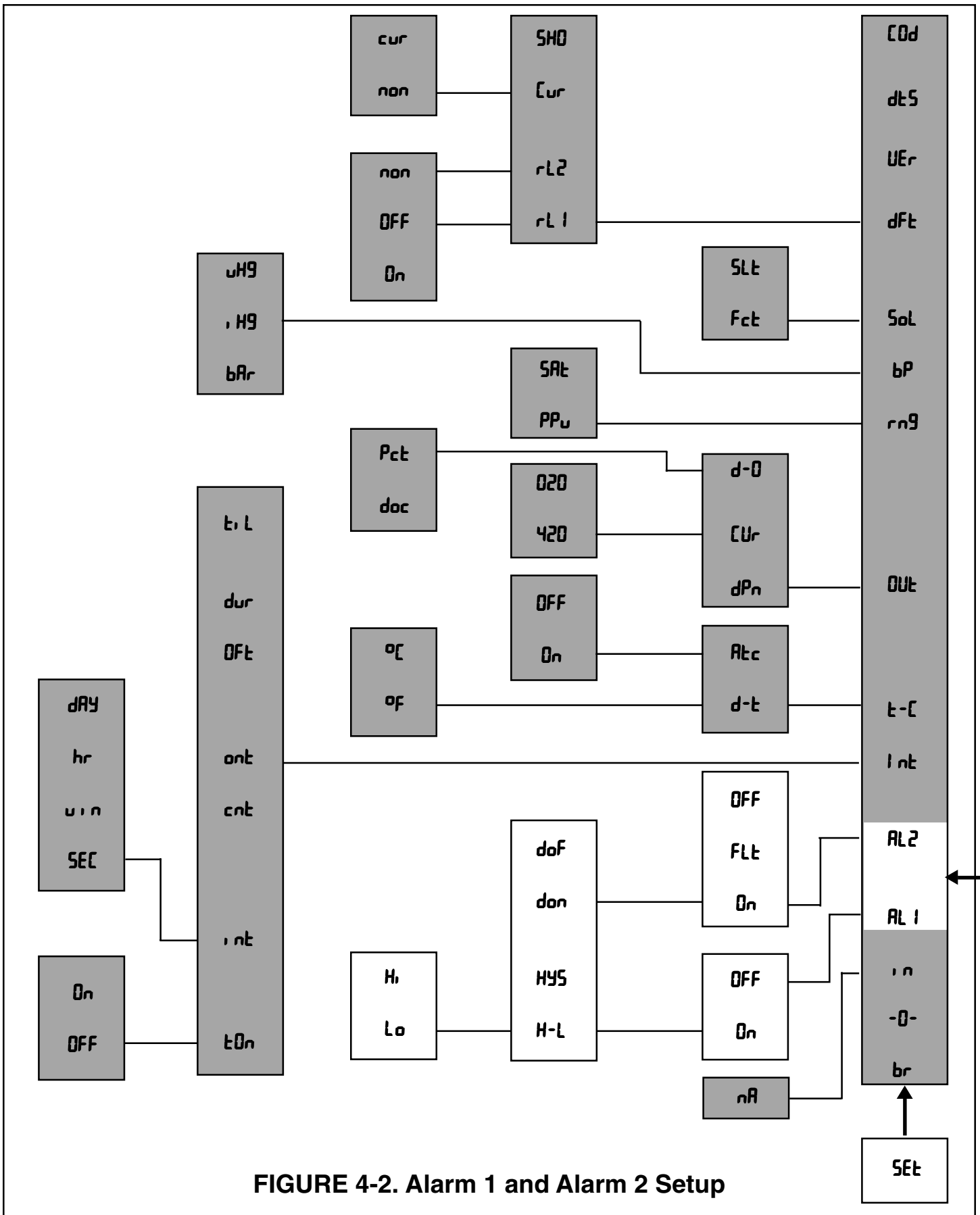

FIGURE 4-2. Alarm 1 and Alarm 2 Setup

4.3 INTERVAL TIMER. Display Mnemonic “i n t”. This item is used to set the interval timer’s relay logic. The timer can be used as a sensor maintenance reminder. Choices are:

A. Interval Timer Enable/Disable. Display Mnemonic “t o n”. Select this item to begin interval cycle “o n” or disable interval cycle “o f f”.

B. Interval Period. Display Mnemonic “i n t”. Select this item to set the time period between end of wait duration and beginning of new on-off cycle. “5 E L” for seconds, “m i n” for minutes, “h r” for hours, and “d a y” for days. May be set from 1 second to 2999 days. **Time of less than 10 minutes is not recommended.**

C. On Periods Per Cycle. Display Mnemonic “c n t”. Select this item to enter the number of on periods per cycle. May be set from 1 to 60 on periods.

D. Duration of On Periods. Display Mnemonic “o n t”. Select this item to enter the relay activation time for each on period. May be set from 0.1 to 299.9 seconds.

E. Duration of Off Periods. Display Mnemonic “o f t”. Select this item to enter the relay deactivation time between each on period during the control cycle. Valid when “c n t” is 2 or greater. May be set from 0.1 second to 299.9 seconds.

F. Wait Duration. Display Mnemonic “d u r”. Select this option to enter the wait duration after the last on period in a cycle. May be set from 0.1 to 299.0 seconds. The wait duration can be used for sensor recovery after a cycle to allow the process to stabilize before the next interval time starts again.

NOTE:

The MODEL 20-03 is placed on hold during the control cycle (from first on period through the wait duration). The transmitter will simulate a fault condition and briefly show “i t r” every eight seconds. The display will continue to show the measured value.

G. Interval Time Remaining. Display Mnemonic “t, l”. Select this item to display the time remaining to the next control cycle. If selected during the control cycle, display will show “—”.

4.3.1 Interval Timer Set Up (i n t). Refer to Figure 4-3.

1. Enter Set Mode by pressing the **ACCESS** key twice.
2. Press the **SCROLL (▲)** key until “i n t” appears on the display.
3. Press the **SELECT (◀)** key to move to the next menu level. “t o n” will display. Press the **SELECT (◀)** key again.
4. Press the **SCROLL (▲)** key to display “o n” (if the interval timer is to be used) or “o f f” (if the interval timer is not to be used) and press the **ENTER** key. If interval timer configuration is required, proceed to Step 5, otherwise Step 15.
5. Press the **SCROLL (▲)** key to display the next menu item, “i n t”. Press the **SELECT (◀)** key.
6. Press the **SCROLL (▲)** key to display desired duration and **SELECT (◀)** it.
7. Press the **SCROLL (▲)** key and **SELECT (◀)** key to display the desired value and press the **ENTER** key.
8. Repeat Steps 6 and 7 as needed.
9. Press the **ENTER** key to return to the interval period “i n t” menu.
10. **SCROLL (▲)** down to “c n t” (on periods per cycle) Press the **SELECT (◀)** key and the current setting will flash. Repeat Step 7.
11. **SCROLL (▲)** down to “o n t” (duration of on times). Press the **SELECT** key and the current setting will flash. Repeat Step 7.
12. **SCROLL (▲)** down to “o f t” (duration of off times). Press the **SELECT (◀)** key and the current setting will flash. Repeat Step 7.
13. **SCROLL (▲)** down to “d u r” (waiting time after the last on cycle). Press the **SELECT (◀)** key and the current setting will flash. Repeat Step 7.
14. **SCROLL (▲)** down to “t, l” (time interval lapse). Press the **SELECT (◀)** key to display the time remaining. Press the **ENTER** key to return to “t, l”.
15. Press the **ENTER** key to return to the first level of the Set Menu, or press the **DO** key to get out of the Set Mode.

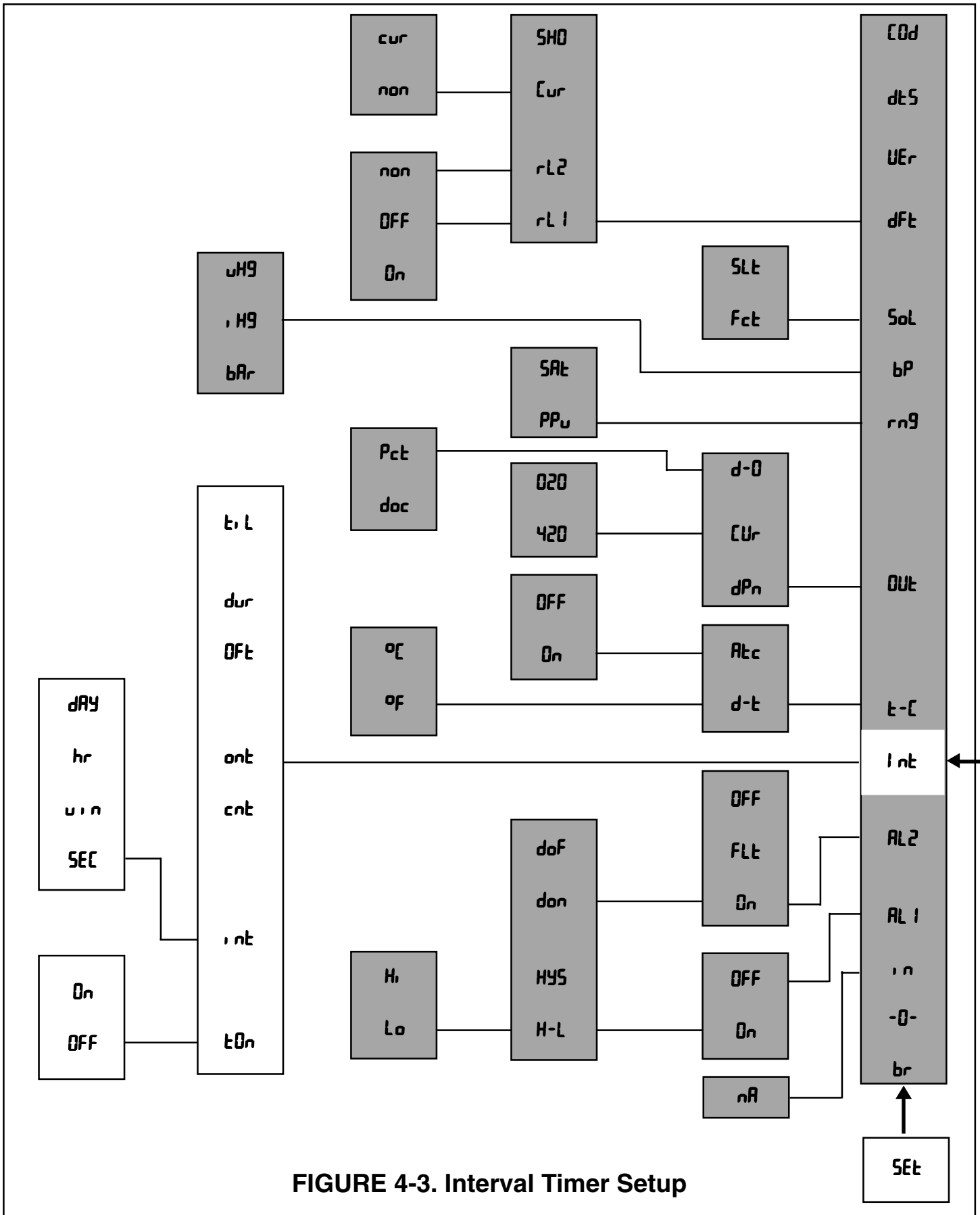

FIGURE 4-3. Interval Timer Setup

4.4 TEMPERATURE CONFIGURATION. Display Mnemonic “t-t”. Select this item for temperature reading and compensation choices.

A. Temperature Display. Display Mnemonic “d-t”. Select this item to toggle between °F and °C temperature display. The transmitter will show all temperatures in the units selected.

B. Automatic Temperature Compensation. Display Mnemonic “RtC”. The transmitter will use the temperature input from the sensor for temperature compensation when “on” is selected. When “oFF” is selected, the transmitter will use the value entered by the user for manual temperature compensation. This manual temperature option is useful if the temperature sensor is faulty or not on line. Temperature specific faults will be disabled. (Refer to Table 8.1.)

4.4.1 Temperature Setup (t-t). Refer to Figure 4-4.

1. Enter Set Mode by pressing the **ACCESS** key twice.
2. Press the **SCROLL** (▲) key until “t-t” appears on the display.
3. Press the **SELECT** (◀) key to move to the next menu level. “d-t” will display.
4. Press the **SELECT** (◀) key. “oF” or “oC” will be displayed flashing. **SCROLL** (▲) to desired unit.
5. Press the **ENTER** key when the desired temperature unit is displayed. The transmitter will now display temperature readings in this unit until changed.
6. **SCROLL** (▲) to “RtC” then press the **SELECT** (◀) key. “on” or “oFF” will be displayed flashing. **SCROLL** (▲) to desired condition.
7. Press the **ENTER** key when the desired condition is displayed.
8. If “on” was entered, proceed to Step 10. If “oFF” was entered, the last temperature used for manual compensation will be displayed with the right digit flashing.
9. Use **SCROLL** (▲) and **SELECT** (◀) to display the desired value. **ENTER** value into memory.
10. Press the **ENTER** key to return to the first level of the Set Menu, or press the **DO** key to get out of the Set Mode.

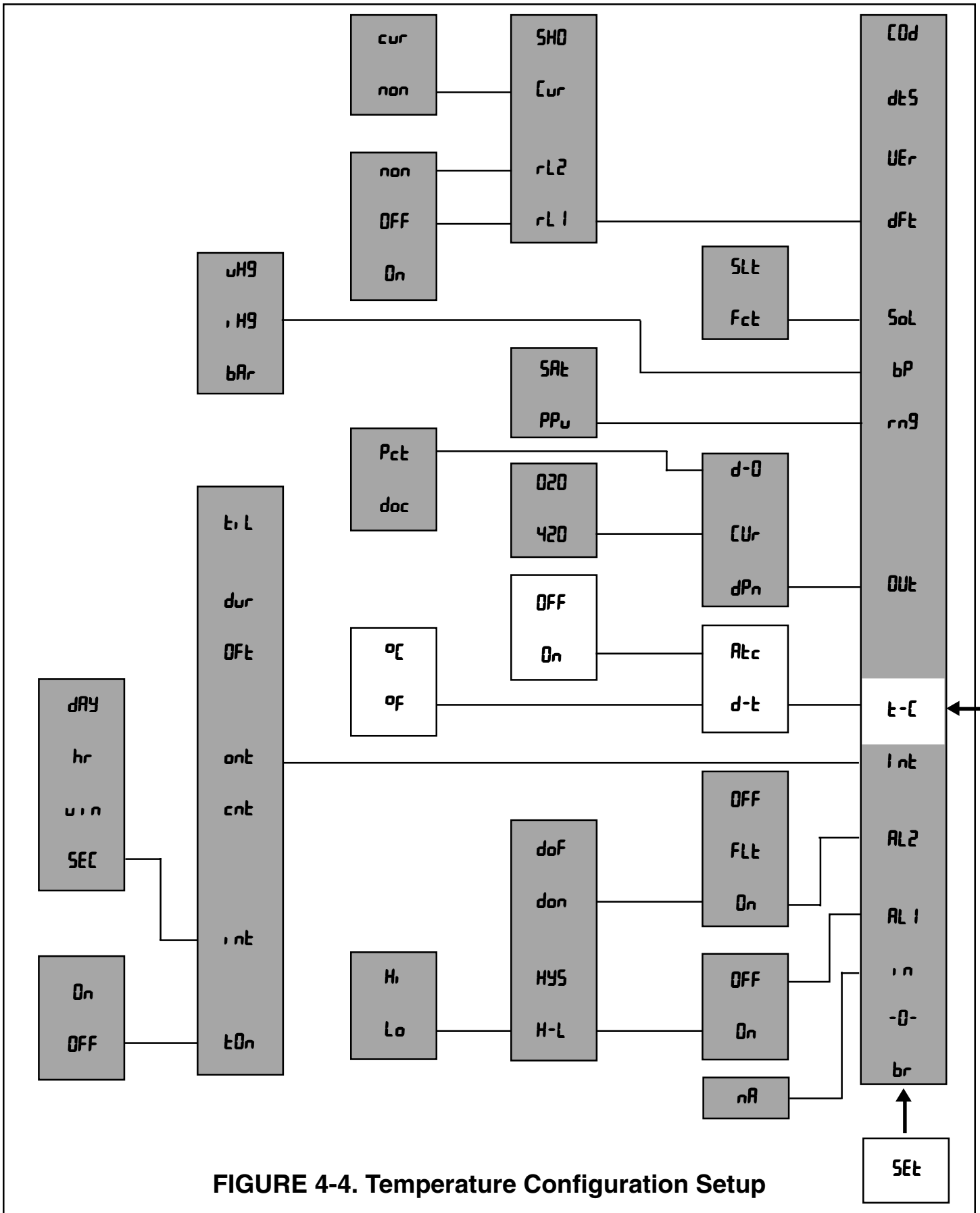

FIGURE 4-4. Temperature Configuration Setup

4.5 CURRENT OUTPUT. Display Mnemonic is "OUT". This item is used to select signal output configuration.

A. Output Dampening. Display Mnemonic "dPn". This function is used to filter out and spread out any change in signal output. The number entered is the sampling time (in seconds). Zero to 255 seconds may be entered. If less than 1 second is entered, the signal output change takes place immediately. If 1 to 255 seconds is entered, 63% of the signal output change takes place in the first sampling time, then 63% of the balance of the signal output change takes place in the next sampling time, etc.

B. mA Output Range. Display Mnemonic "CUR". Selection of this item will allow choice of either 0 to 20 mA or 4 to 20 mA output range.

C. Display Output. Display Mnemonic "d-U". This item is used to select output display logic. Selecting this item will allow the transmitter to display current output in mA (when "dAc" is entered) or in percent of full scale output range (when "Pct" is entered). When the **OUTPUT** key is pressed, a steady flag indicates that the value displayed is percent output. A flashing flag indicates mA output.

4.5.1 Output Setup (OUT). Refer to Figure 4-5.

1. Enter Set Mode by pressing the **ACCESS** key twice.
2. Press the **SCROLL** (▲) key until "OUT" appears on the display.
3. Press the **SELECT** (◀) key to move to the next menu level. "dPn" will display.
4. Press the **SCROLL** (▲) key then **SELECT** (◀) desired item.
5. If "dPn" is selected, numerical display will flash indicating that a value is required. Proceed to Step 6.
If "CUR" or "d-U" is selected, proceed to Step 7.
6. Use **SCROLL** (▲) and **SELECT** (◀) keys to display the desired value. **ENTER** into memory. Proceed to Step 11.
7. If "CUR" is selected, "420" or "020" is displayed flashing.
8. **SCROLL** (▲) to the desired mA choice and press **ENTER**. Proceed to Step 11.
9. If "d-U" is selected, "Pct" or "dAc" is displayed flashing.
10. **SCROLL** (▲) to the desired output unit and press **ENTER**.
11. Press the **ENTER** key to return to the first level of the Set Menu, or press the **DO** key to get out of the Set Mode.

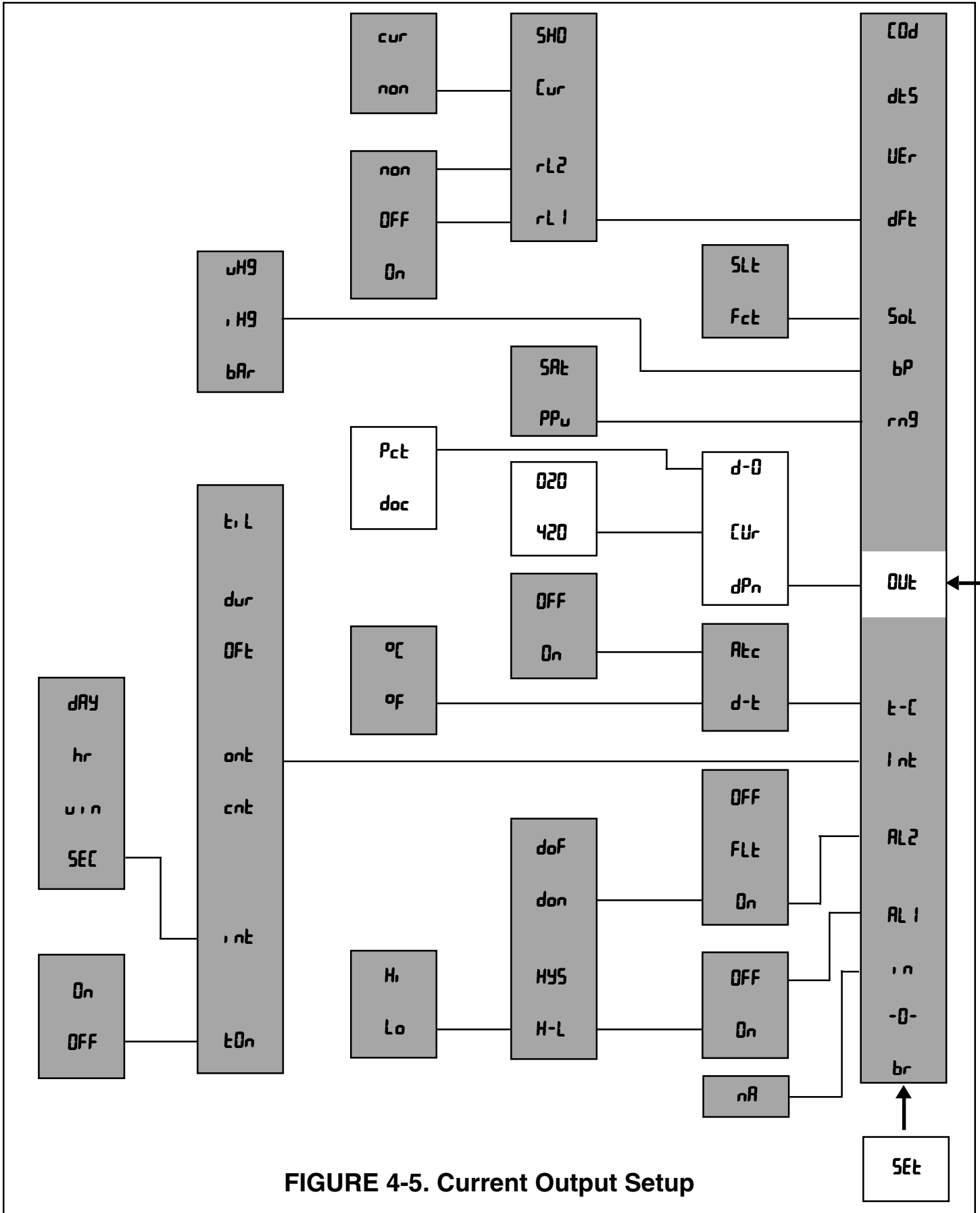

FIGURE 4-5. Current Output Setup

4.6 DISSOLVED OXYGEN RANGE UNITS. Display Mnemonic “rng”. This function is used to select the desired dissolved oxygen range units. One of the following two range units may be chosen:

A. (ppm) Display Mnemonic “PPU”. Selecting this item is for parts per million by weight of dissolved oxygen concentration. This mode is recommended for measurements in the following:

- Water
- Salt water where the % salinity has been entered via the solubility correction factor “SLT” (see Section 4.8.1)
- Process liquid whose oxygen solubility changes with temperature in a direct proportion with water and that proportion or factor has been entered via the solubility correction factor “FCT” (see Section 4.8.1)

The explanation for the above recommendations is that when in the “ppm” mode the MODEL 20-03 automatically calculates the effects of both barometric pressure and temperature on oxygen solubility in water.

Example - When calibrating the OxyProbe® dissolved oxygen sensor (in room air or in air-saturated water) while in the “ppm” mode, begin by pressing the “CAL” key. The MODEL 20-03 will request the entry of the current barometric pressure. The MODEL 20-03, using the temperature information from the sensor with the recently entered barometric pressure, will calculate the oxygen concentration in water at this temperature and pressure. At 1 atmosphere (14.7 psi) and 24°C, water will hold 8.4 ppm of oxygen which will be indicated on the transmitter.

Placing the sensor in air saturated water at 2°C, the sensor will detect the same partial pressure while the MODEL 20-03 will automatically correct for the change in oxygen solubility in water due to temperature change. At 1 atmosphere (14.7 psi) and 2°C, water holds 13.8 ppm of oxygen which will accordingly be displayed on the transmitter.

To measure in liquids other than water while in the “ppm” mode, the temperature must remain constant throughout the process. If the temperature is not constant, the “% Saturation” mode should be selected.

B. % Saturation Display Mnemonic “SRt”. % saturation is the percent of dissolved oxygen in solution compared to the maximum amount of dissolved oxygen the solution can hold at a given temperature and partial pressure of oxygen. If the process liquid is at normal barometric pressure and is saturated with air, it is said to be 100% saturated. If % O2 is desired, select the “SRt” option and follow the instructions for % Saturation Standardization in Section 5.3.4.3.

NOTE

Dissolved oxygen values will be displayed in the unit selected until changed.

4.6.1 Dissolved Oxygen Transmitter Set Up “rng”. Refer to Figure 4-6.

1. Enter Set Mode by pressing the **ACCESS** key twice.
2. Press the **SCROLL (▲)** key until “rng” appears on the display.
3. Press the **SELECT(◀)** key. “PPU” or “SRt” will be displayed.
4. Press the **SCROLL (▲)** key to display the desired range unit.
5. Press the **ENTER** key to enter the desired unit into memory.
6. Press the **ENTER** key to return to the first level of the Set Menu, or press the **DO** key to get out of the Set Mode.

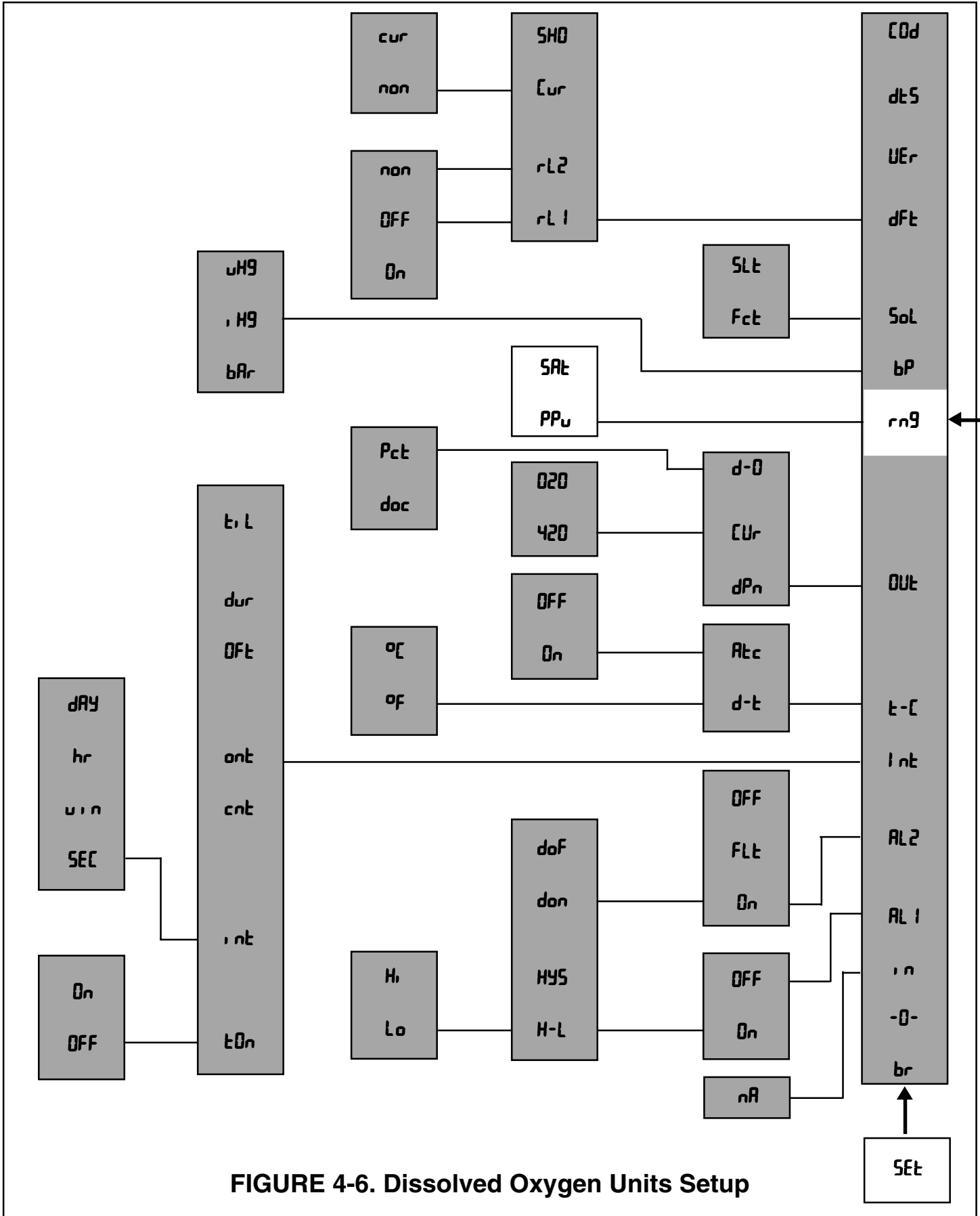

FIGURE 4-6. Dissolved Oxygen Units Setup

4.7 BAROMETRIC PRESSURE UNITS. Display Mnemonic “bP”. This function is used to select the barometric pressure units needed by the microprocessor during the air calibration step. One of the following three range units may be chosen:

- A. “bRr” if the barometric pressure is given in bars.
- B. “i Hg” if the barometric pressure is given in inches of mercury.
- C. “mHg” if the barometric pressure is given in millimeters of mercury.

4.7.1 Barometric Pressure Unit Set Up “bP”. Refer to Figure 4-7.

1. Enter Set Mode by pressing the **ACCESS** key twice
2. Press the **SCROLL (▲)** key until “bP” appears on the display.
3. Press the **SELECT (◀)** key. “mHg”, “i Hg” or “bRr” will be displayed flashing.
4. Press the **SCROLL (▲)** key to display the desired barometric pressure unit.
5. Press the enter key to enter the desired unit into memory.
6. Press the **ENTER** key to return to the first level of the Set Menu, or press the **DO** key to get out of the Set Mode.

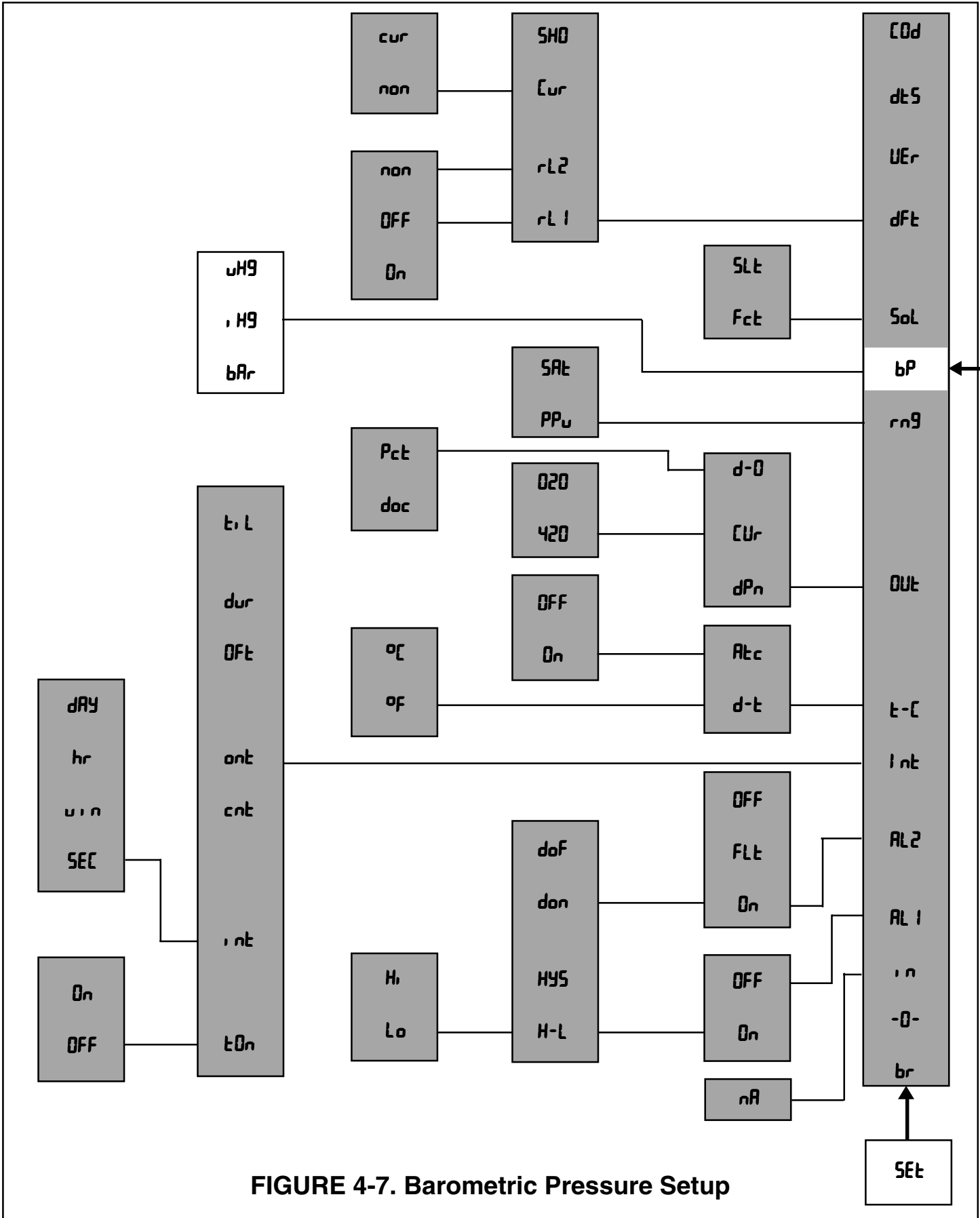

FIGURE 4-7. Barometric Pressure Setup

4.8 SOLUBILITY CORRECTION FACTOR. Display Mnemonic "SOL". This function is used to correct for the solubility of oxygen in the process liquid which is other than fresh water or is unique to the customer. One of the following two factors may be chosen:

A. "Fct" – Solubility constant of the process liquid. **For fresh water, enter a value of 1.00.** (The solubility constant "Fct" range is 0.09 to 9.00.) A value of 2 would be used for a solution which had twice the solubility of oxygen in water.

B. "Sl" – The salinity of the liquid measured in parts per thousand by weight of salt. **For fresh water, enter a value of 0.00.** (The typical parts per thousand salt by weight range is 0.00 to 2.00.)

NOTE

10 ppt (10,000 ppm) of salt is equivalent to 1.00 percent salt.

4.8.1 Solubility Correction Factor Set Up "Sol". Refer to Figure 4-8.

1. Enter Set Mode by pressing the **ACCESS** key twice.
2. Press the **SCROLL (▲)** key until "Sol" appears on the display.
3. Press the **SELECT (◀)** key. "Fct" or "Sl" will be displayed. Press the **SCROLL (▲)** key to display the desired choice.
4. Press **SELECT (◀)** key. The last choice used will be displayed flashing.
5. Use the **SCROLL (▲)** and **SELECT (◀)** keys to display the desired value. Press the enter key to enter the value into memory.
6. Press the **ENTER** key to return to the first level of the Set Menu, or press the **DO** key to get out of the Set Mode.

NOTE

Dissolved oxygen values will now be corrected according to the current factor value entered until new values are entered.

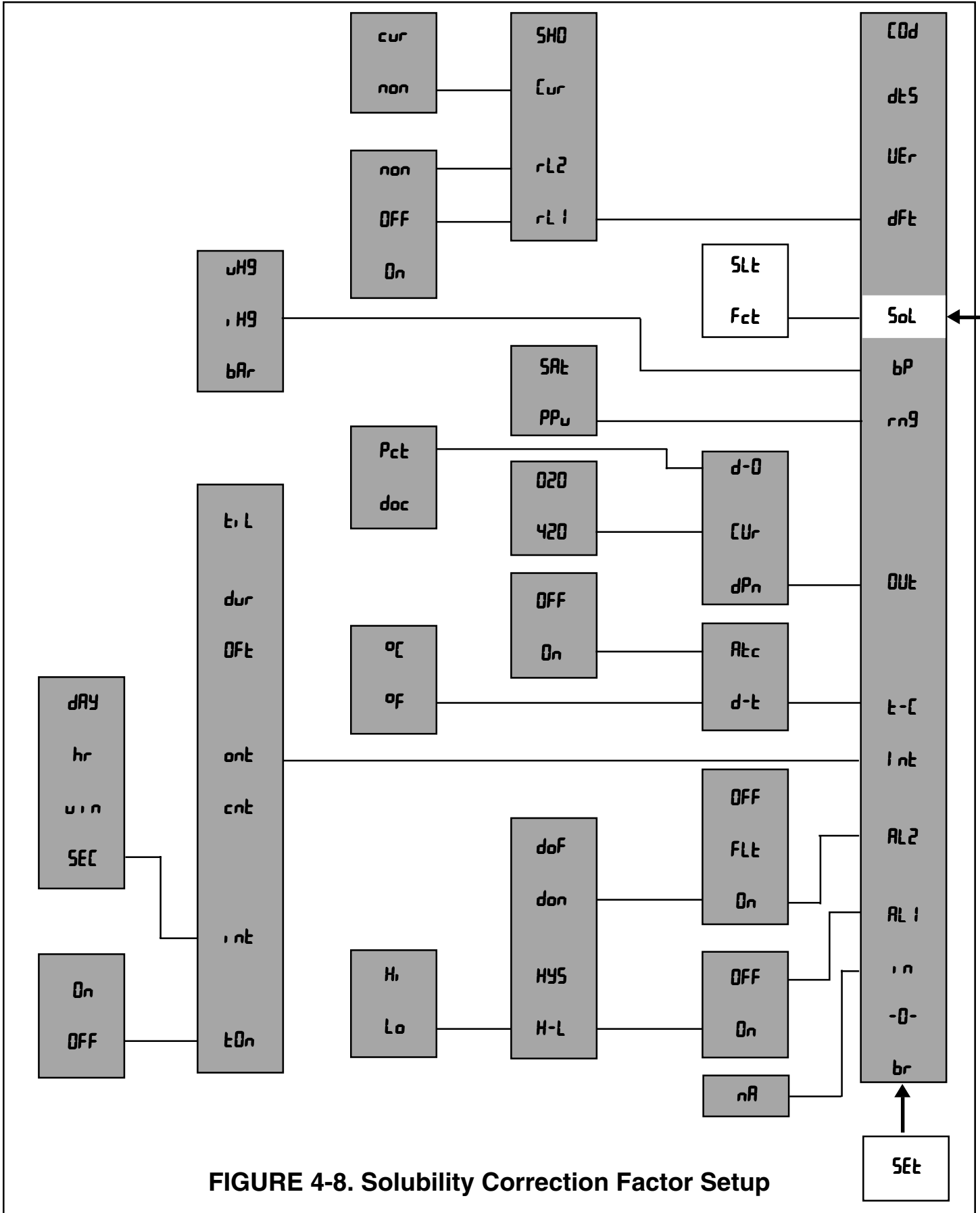

FIGURE 4-8. Solubility Correction Factor Setup

4.10 DEFAULTS. Display Mnemonic “dFt”. This function is used to set the configuration of relay and output conditions during a FAULT or HOLD status. A flashing flag beside the HOLD/FAULT label indicates a fault condition.

A. Relays 1 and 2. Display Mnemonic “rL 1” and “rL 2”. The relays can be set to activate “on”, deactivate “off”, or hold present status “non”.

When “on” is chosen, the relay will be activated at a FAULT or HOLD condition.

When “off” is chosen, the relay will be deactivated at a FAULT or HOLD condition.

When “non” is chosen, the relay will maintain its status during a FAULT or HOLD condition.

B. Current Output. Display Mnemonic “cur”. This item is used to configure the transmitter’s output during a FAULT or a HOLD condition. There are two selections: “non” and “cur”. When “non” is chosen, the present output is frozen at a FAULT or HOLD condition. When “cur” is chosen, the transmitter uses the milliamp value the user has entered to be the output during a FAULT or HOLD condition.

C. Fault History. Display Mnemonic “SHD”. Selecting this item will allow the user to view all the faults of the two most recent fault conditions that have occurred since the last reset viewing.

4.10.1 Default Setup (dFt). Refer to Figure 4-10.

1. Enter Set Mode by pressing the **ACCESS** key twice.
2. Press the **SCROLL** (▲) key until “dFt” appears on the display.
3. Press the **SELECT** (◀) key to move to the next menu level. “rL 1” will display.
4. Press the **SCROLL** (▲) key to display desired item then press the **SELECT** (◀) key.
5. When “rL 1” or “rL 2” is selected, “non”, “off”, or “on” is displayed flashing. Press the **SCROLL** (▲) key to display the desired condition and press the **ENTER** key to enter the selection into memory.
6. When “cur” is selected, “non” or “cur” is displayed flashing. Press the **SCROLL** (▲) key to display the desired condition and press the **ENTER** key to enter the selection into memory. When “cur” is entered, the mA value in memory is displayed with the right digit flashing. Use **SCROLL** (▲) and **SELECT** (◀) to display the desired value and press the **ENTER** key to enter this value into memory.
7. When “SHD” is selected, press the **SELECT** (◀) key to view the fault history. Pressing the **ENTER** key will erase the list from memory. A new list is started as new faults occur.
8. Press the **ENTER** key to return to the first level of the Set Menu, or press the **DO** key to get out of the Set Mode.

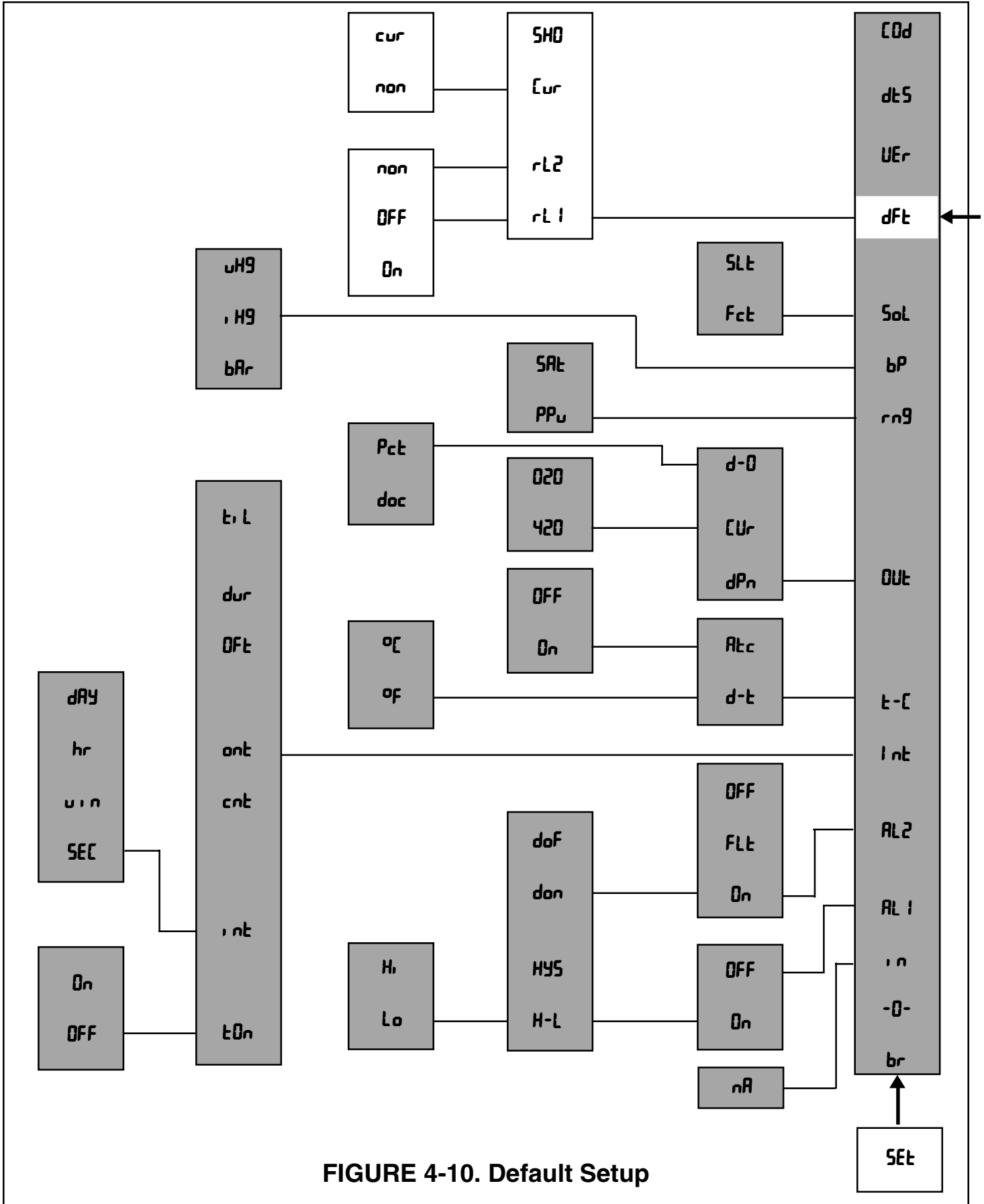

FIGURE 4-10. Default Setup

4.11 SOFTWARE VERSION NUMBER. Display Mnemonic “UEr”. This function displays the software version number used in the particular transmitter being used. This information may be very important in servicing the transmitter.

4.11.1 To Display Software Version Number.

1. Enter Set Mode by pressing the **ACCESS** key twice.
2. Press the **SCROLL** (▲) key until “UEr” appears on the display.
3. Press the **SELECT** (◀) key and the software version number will be displayed.
4. Press the **ENTER** key to return to the first level of the Set Menu, or press the **DO** key to get out of the Set Mode.

4.12 Display test. Display Mnemonic “dt5”. This function allows the user to visually test the LED display segments. If the display is functioning properly, all the LED segments are activated.

1. Enter Set Mode by pressing the **ACCESS** key twice.
2. Press the **SCROLL** (▲) key until “dt5” appears on the display.
3. Press the **SELECT** (◀) key and all the LED segments will be displayed for about 5 seconds.
4. Press the **ENTER** key to return to the first level of the Set Menu, or press the **DO** key to get out of the Set Mode.

4.13 ALARM SETPOINT. The alarm setpoints should be adjusted after completing the configuration procedure as outlined in Sections 4.2 to 4.10.

1. Press the **DO** key to ensure that the transmitter is not in Set Mode.
2. Press the **ALARM 1** or **ALARM 2** key. "SP 1" or "SP 2" will show briefly, followed by the Alarm 1 or Alarm 2 setpoint currently in memory.

NOTE

If the alarm is set to OFF or FAULT ("FL 2" only), the transmitter will display "OFF" or "FL 2" respectively. No setpoint value can be entered unless "on" has been selected in the "set menu". (Refer to Section 4.2, Alarm Setup.)

3. Press the **SELECT** (◀) key to adjust the value. The display will acknowledge briefly with "RdJ" followed by the numeric display with right digit flashing.
4. **SCROLL** (▲) and **SELECT** (◀) to display the desired setpoint.
5. Press **ENTER**. "SP 1" or "SP 2" will show briefly, then the desired setpoint is displayed.

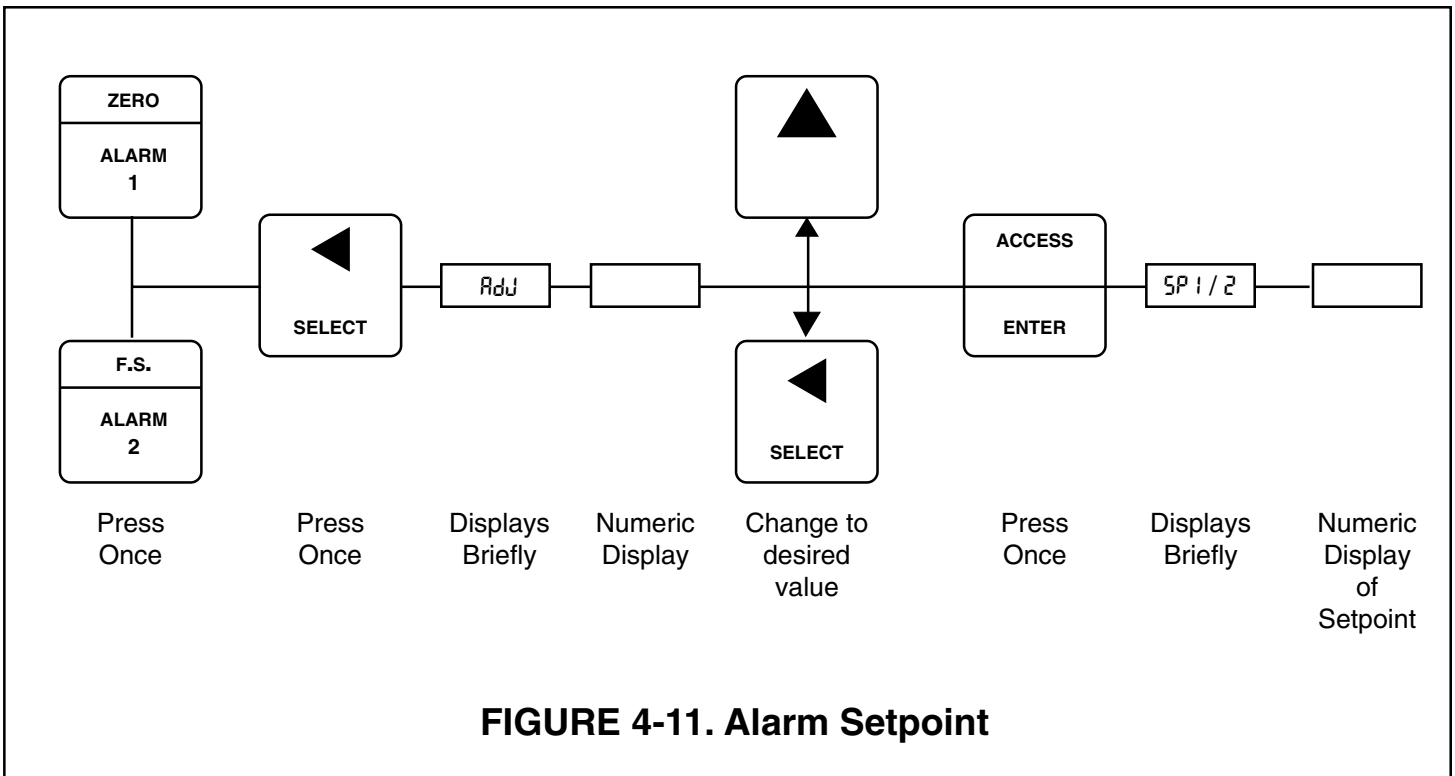

FIGURE 4-11. Alarm Setpoint

4.14 OUTPUT SCALE EXPANSION. This section should be followed only if the current output needs to be scaled to an operating range other than the factory setting of 0-20 ppm dissolved oxygen. The output zero and full scale value should be adjusted after completing the configuration procedure as outlined in Sections 4.2 to 4.10.

A. Zero Setpoint. This is the low dissolved oxygen value that the user wants to correspond to 0 or 4 mA DC output. To change the setpoint, perform the following steps:

1. Press the **DO** key to ensure that the transmitter is not in Set Mode.
2. Press the **ZERO** key. "LD" will show briefly, followed by the ZERO DO value in memory.
3. Press the **SELECT** (◀) key to adjust the value. The display will acknowledge briefly with "RdJ" followed by the numeric display with right digit flashing.
4. **SCROLL** (▲) and **SELECT** (◀) to display the desired setpoint.
5. Press **ENTER**. "HI" will show briefly, then the desired DO value is entered into memory and displayed.

B. Full Scale Setpoint. This is the high dissolved oxygen value that the user wants to correspond to 20 mA DC output. To change the setpoint, perform the following steps:

1. Press the **DO** key to ensure that the transmitter is not in Set Mode.
2. Press the **F.S.** key. "HI" will show briefly, followed by the FULL SCALE DO value.
3. Press the **SELECT** (◀) key to adjust the value. The display will acknowledge briefly with "RdJ" followed by the numeric display with right digit flashing.
4. **SCROLL** (▲) and **SELECT** (◀) to display the desired setpoint.
5. Press **ENTER**. "HI" will show briefly, then the desired DO value is entered into memory and displayed.

NOTE

For reverse output, enter the higher value for zero, and the lower value for the F.S.

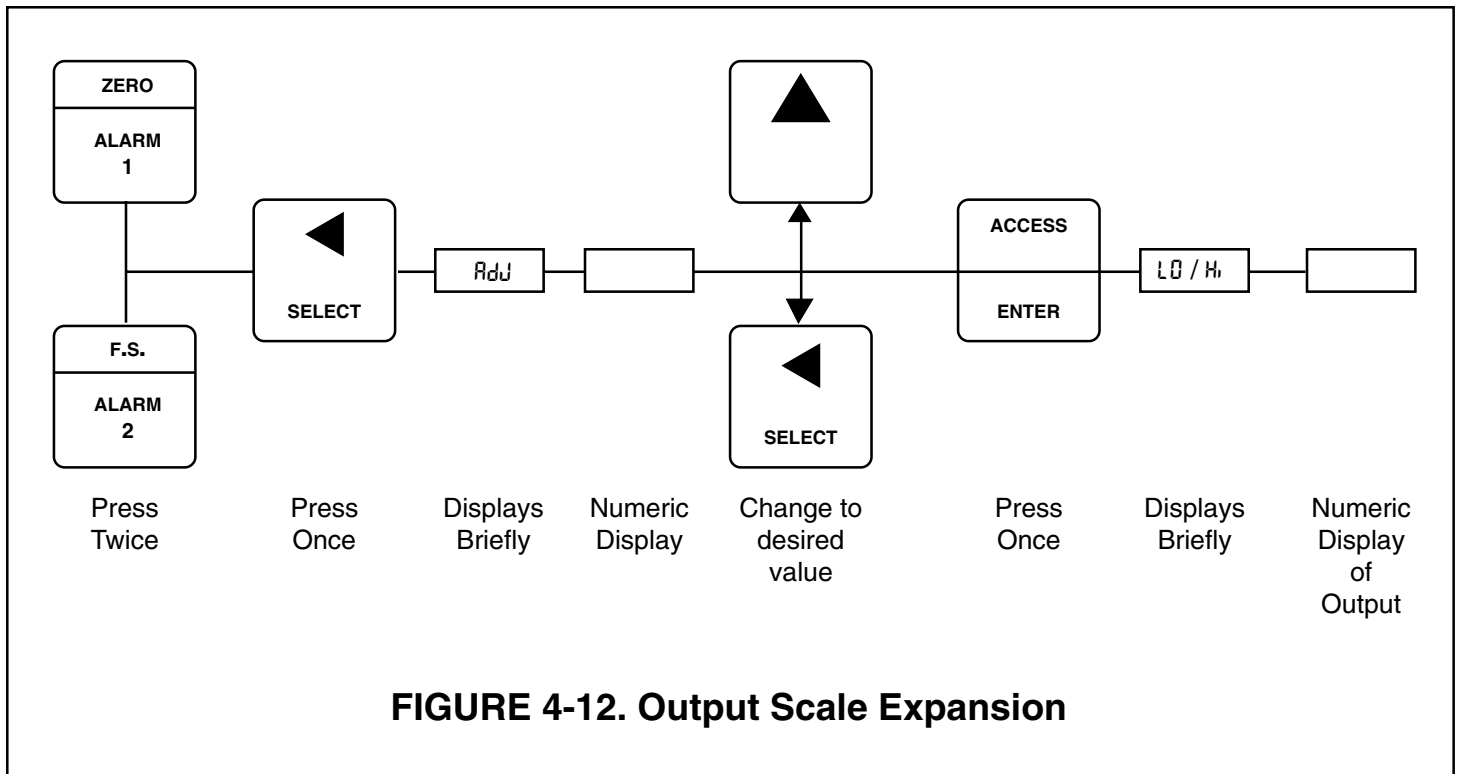

FIGURE 4-12. Output Scale Expansion

4.15 OUTPUT DISPLAY/OUTPUT SIMULATION. The output may be displayed by pressing the **OUTPUT** key. The output is displayed in either milliamp DC or in percent, depending on the output unit selected in the $dFt \rightarrow \text{d-0}$ menu. Refer to Section 4.5.1.

Output simulation allows the user to simulate the current output to test the operation of the devices connected to the output terminals TB3-1 and TB3-2.

Perform the following steps to display output and to simulate output:

1. Press the **OUTPUT** key to display the output. “ $d00$ ” or “ Pct ” will show briefly, then the output is displayed either in milliamp DC or in percent output.

CAUTION

Pressing the **SELECT** (\blacktriangleleft) key to enter the simulation mode will make the transmitter immediately transmit an output equivalent to the simulation value in memory.

2. Press the **SELECT** (\blacktriangleleft) key once. “ $5, \text{I}$ ” (for current output simulation) or “ $5, P$ ” (for percent output simulation) will show briefly, then the simulation value in memory is displayed with right digit flashing. The transmitter is put on HOLD at this time.
3. **SCROLL** (\blacktriangle) and **SELECT** (\blacktriangleleft) to display the desired simulation value.
4. Press **ENTER**. “ $d00$ ” or “ Pct ” will show briefly, then the desired simulation value is displayed flashing and takes effect until the transmitter is taken out of HOLD status. Press **HOLD** twice to remove the transmitter from HOLD status.

4.16 HOLD. Press **HOLD** twice to put the transmitter on HOLD, or to get the transmitter out of HOLD. The transmitter is on HOLD when the HOLD/FAULT flag is steady. Putting the transmitter on HOLD will result in the following:

- A. If “ non ” was chosen in the $dFt \rightarrow \text{Cur}$ menu, the present process current output is frozen until the transmitter is out of HOLD status
- B. If “ cur ” was chosen in the $dFt \rightarrow \text{Cur}$ menu, the present current output will switch (default) to the value entered for current output default.

During a HOLD status, the transmitter may be calibrated or configured. The new values will take effect only after the transmitter is taken out of the HOLD condition.

NOTES

SECTION 5.0 START-UP AND CALIBRATION

5.1 GENERAL. This section provides the start-up and calibration procedures for the MODEL 20-03 Dissolved Oxygen Transmitter with its compatible line of OxyProbe® DO Sensors. The start-up and calibration procedures must be performed only after the installation (Section 2.0) and Configuration (Section 4.0) sections have been properly carried out. Please refer to the OxyProbe instruction Manual P1431 for additional information regarding calibration.

5.2 START-UP. The start-up procedure for the MODEL 20-03 involves the configuration of the transmitter to your particular process requirements and logging the various setpoints in the user column of the Configuration Worksheet. Also involved is the complete polarization of the DO sensor.

When the transmitter is powered up, a polarizing voltage is applied between the sensor's anode and cathode. The sensor (electrode) current is initially very high, then quickly falls off and settles to a steady state after a few hours.

It is recommended that the transmitter remains powered up to the sensor while preparing for calibration or while undergoing routine maintenance. Sensor life will not be shortened under these conditions because only a very small current flows through the sensor. If for any reason the sensor has to be disconnected (or the transmitter switched off) the sensor will have to be polarized before it can be ready for further operation.

IMPORTANT NOTE

The first time the transmitter is powered up with a sensor installed, "Err" may be flashing. Press the **CAL** key, then the **SELECT** (◀) key, and then press enter to remove this fault.

5.3 CALIBRATION.

The solubility of O₂ is dependent on temperature and pressure. The MODEL 20-03 automatically compensates for temperature changes and can be manually compensated for changes in pressure which can be entered as process or atmospheric pressure. In % Saturation or ppm, the MODEL 20-03 will provide the corrected reading.

For measurement readouts in ppm, setting the ambient atmospheric pressure at the time calibration is performed will be sufficient to assure accurate readings. Normal changes in atmospheric pressure will result in at most a 10% change in O₂ solubility. When using the ppm mode, calibration is the only time the process or atmospheric pressure need to be entered.

For measurements in the % Saturation mode, the calibration pressure will define what 100% saturation is. % Saturation is a relative measurement, therefore, changes in process pressure can change what 100% saturation is. If the process pressure changes significantly, it must be corrected by entering the new process pressure in accordance with the configuration procedures in Section 4.7. No further correction is required if the system is calibrated at the same pressure that the measurement will be made and no pressure change has occurred since calibration.

5.3.1 Temperature Calibration. For accurate temperature compensation and temperature readings, the TEMP function of the transmitter must be calibrated.

1. Place the sensor in a container filled adequately with process sample or any known solution.
2. Place a calibrated temperature reading device in the sample container.
3. Allow the readings to stabilize.
4. When the readings are stable, compare the transmitter's reading to that of the calibrated temperature indicating device.

If the transmitter's reading requires adjusting, follow these steps:

1. Press the **DO** key to ensure that the transmitter is not in Set Mode.
2. Press the **TEMP** key once. "0F" or "0C" will show briefly, then the present temperature is displayed in either °F or °C (depending on the unit selected in the $t \rightarrow d \rightarrow t$ menu).

3. Press the **SELECT** (◀) key to adjust the value. The display will acknowledge briefly with "RdJ" followed by the numeric display with right digit flashing.
4. **SCROLL** (▲) and **SELECT** (◀) to display the desired correct temperature.
5. Press **ENTER**. "°F" or "°C" will show briefly, then the solution temperature is displayed.

5.3.2 Transmitter Zero. This procedure is required to electronically zero the transmitter/sensor loop. There are two methods of setting the transmitter zero; (1) zero the transmitter only; and (2) zero the transmitter and sensor as a loop.

Method 1: Transmitter Only

Method 1 is recommended for measurement of O_2 levels > 50% SAT while maintaining a precision level of approximately 1%.

Example: Fermentation Process

Preparation: Disconnect cable from sensor. To maintain polarization of sensor attach OxyProbe® Polarizing Unit, P/N: AM-9221 to sensor. Leave the sensor cable connected to the transmitter being certain that nothing is connected to the sensor end of the cable.

Procedure: Set the transmitter zero according to steps 3 through 6 below. Reconnect the sensor to the transmitter and proceed to Section 5.3.3, ppm Calibration, or Section 5.3.4, % Saturation Calibration.

Method 2: Transmitter & Sensor

Method 2 is recommended for measurement of O_2 levels ($O_2 > 1\text{ppm}$) while maintaining optimal precision over the full range.

Example: Brewery Process

In order to eliminate any residual current in the loop the sensor must be placed in a zero DO solution and remain there for a minimum of 12 to 24 hours before adjusting the transmitter zero (0 ppm or 0% saturation).

1. Place the sensor in a sodium sulfite solution (1 gram or about 1/10 teaspoonful to a liter of water) or in pure nitrogen gas.
2. Allow the sensor to stabilize in the zero DO environment.
3. Press the **ACCESS** key twice to enter the Set Mode.
4. Press the **SCROLL** (▲) key until "-0-" is displayed.
5. Press the **SELECT** (◀) key. "-0-" will flash for about five seconds and then freeze. The transmitter loop is now zeroed.
6. Press the **ENTER** key to return to the first level of the Set Menu, or press the **DO** key to get out of the Set Mode.
7. Remove the sensor from the solution. Gently clean and dry the sensor.
8. Proceed to Section 5.3.3, ppm Calibration, or Section 5.3.4, % Saturation Calibration.

5.3.3 ppm Calibration.

5.3.3.1 Air Calibration The MODEL 20-03 Transmitter and the appropriate DO Sensor loop may be air calibrated quite easily.

1. Place the sensor in ambient air. If not already done select the transmitter display range for ppm as in Section 4.6.
2. Make sure the sensor is clean, dry and in good condition. Make sure the sensor is completely polarized (at least 2 hours). For optimum results, the loop should be powered overnight.
3. Determine the present barometric pressure in your area in one of the following units: bars, inches of mercury, or millimeters of mercury.
4. Press the **CAL** key. The units of pressure selected in the “bP” menu appears briefly and then the value in memory is displayed (Refer to Section 4.7.1).
5. Press the **SELECT** (◀) key. “5t d” appears briefly and then the barometric pressure value in memory is displayed with the right digit flashing.
6. Use **SCROLL** (▲) and **SELECT** (◀) keys to display the correct barometric pressure.
7. Press **ENTER**. Press the **DO** key. The oxygen concentration in air is then displayed in ppm. This value has been automatically selected from the internal solubility tables for the oxygen solubility in pure water at the previously set temperature and pressure. (This value has also been corrected for process solubility if a process solubility factor has been entered per Section 4.8 .)
8. The sensor may now be installed in the process. Please refer to the sensor instruction manual for proper installation of the sensor.

CAUTION

NEVER air calibrate with the sensor in process. This will result in erroneous readings.

5.3.3.2 Grab Sample ppm Standardization.

Air calibration is sufficient for most applications. For greater accuracy, the sensor may be standardized using a grab sample. Single point standardization when ppm (P_u) is chosen is done with the **DO** key.

Procedure:

1. Place the sensor in process or in a grab sample. Allow it to stabilize. Note, during this procedure the pressure and temperature of the process cannot vary.
2. When the transmitter’s reading is stable, note the reading. Perform an analysis of the process or grab sample as quickly as possible using a known good laboratory standard test apparatus, making sure that the sample is protected from exposure to air.
3. Note the current DO reading. If it has not changed from the time the sample was taken, proceed to step 5.
4. If the DO reading has changed from the time the sample was taken, use the formula shown in Figure 5-1 to determine the calibration value used in Step 5 C.
5. Standardize the unit loop to the value obtained from the chemical analysis as follows:
 - A. Press the **DO** key.
 - B. Press the **SELECT** (◀) key. “5t d” appears briefly and then the last dissolved oxygen value is displayed with the right digit flashing.
 - C. Use **SCROLL** (▲) and **SELECT** (◀) keys to display the true value from the chemical analysis.
 - D. Press the **ENTER** key. The loop is now standardized.

$$\text{DO Calibration Value} = \frac{\text{Transmitter DO Reading at Calibration}}{\text{Transmitter DO Reading at Sampling}} \times \text{DO from Chemical Analysis}$$

FIGURE 5-1. DO Standardization Formula

5.3.4 % Saturation Calibration

5.3.4.1 Air Calibration.

The MODEL 20-03 Transmitter and the appropriate DO Sensor loop may be air calibrated quite easily.

1. Place the sensor in ambient air. If not already done select the transmitter display range for % SAT as in Section 4.6.
2. Make sure the sensor is clean, dry and in good condition. Make sure the sensor is completely polarized (at least 2 hours). For optimum results, the loop should be powered overnight.
3. Determine the present barometric pressure in your area in one of the following units: bars, inches of mercury, or millimeters of mercury.
4. Press the **CAL** key. The units of pressure selected in "bP" menu appears briefly and then the value in memory is displayed (Refer to Section 4.7.1).
5. Press the **SELECT** (◀) key. "5Ed" appears briefly and then the barometric pressure value in memory is displayed with the right digit flashing.
6. Use **SCROLL** (▲) and **SELECT** (◀) keys to display the correct barometric pressure.
7. Press **ENTER**. Press the **DO** key. The oxygen concentration in air is then displayed in % SAT. This value has been automatically selected from the internal solubility tables for the oxygen solubility in pure water at the previously set temperature and pressure. (This value has also been corrected for process solubility if a process solubility factor has been entered per Section 4.8 .)
8. The sensor may now be installed in the process. Please refer to the sensor instruction manual for proper installation of the sensor.

CAUTION

NEVER air calibrate with the sensor in process. This will result in erroneous readings.

5.3.4.2 Update Barometric Pressure.

This function is used to update the barometric pressure after the transmitter/sensor loop has been air calibrated and the sensor is installed in the process.

1. Allow the reading to stabilize.
2. Press the **ACCESS** key twice to enter the Set Mode. "5Et" will show briefly, then "br".
3. Press the **SELECT** (◀) key. The barometric pressure value in memory will be displayed with the right digit flashing.
4. Use the **SCROLL** (▲) and **SELECT** (◀) key to display the current barometric pressure value. Press the **ENTER** key.

5.3.4.3 % Saturation Standardization.

Air calibration is sufficient for many applications. For greater accuracy, the sensor may be standardized in process.

1. Install the sensor and perform a barometric update.
 - a. Allow the reading to stabilize.
 - b. Press the **ACCESS** key twice to enter the Set Mode. "5Et" will show briefly, then "br".
 - c. Press the **SELECT** (◀) key. The barometric pressure value in memory entered will be displayed with the right digit flashing.
 - d. Use the **SCROLL** (▲) and the **SELECT** (◀) key to display the current barometric pressure value. Press the **ENTER** key.
2. To standardize the sensor, the % saturation of the process must be known.
3. When the transmitter's reading is stable, perform the standardization as follows:
 - A. Press the **DO** key.
 - B. Press the **SELECT** (◀) key. "5Ed" appears briefly and the last % saturation value is displayed with the right digit flashing.

C. Use **SCROLL** (▲) and **SELECT** (◀) keys as required to display the processes % saturation.

D. Press the **ENTER** key. The loop is now standardized.

5.4 CALIBRATION FOR FERMENTATION APPLICATIONS.

The dissolved oxygen measuring loop including sensor, cable, and transmitter should be recalibrated prior to each fermentation run. If work is performed under sterile conditions, the loop should be calibrated with the sensor in place after sterilization. The sterilization process could alter the sensor output.

It is always best to adjust the zero point prior to air calibration or standardization. It is preferred that the calibration be done in the aqueous phase due to the following problems that arise when this calibration is done in air:

- Membrane permeability slightly differs in air versus water.
- Ambient relative humidity of air is rarely 100%

A solution saturated with air is defined as 100% saturated. In large size aerated fermenters the sensor should be calibrated in place after sterilization. Calibration should be carried out under flow, aeration, and pressure conditions which are representative of those encountered during the actual process run.

SECTION 6.0 KEYBOARD SECURITY

6.1 KEYBOARD SECURITY.

Display Mnemonic “**Ed**”. Select this feature to display the user defined security code. Any three digit number may be used for this code. “**000**” will disable the security feature. This item is used to prevent accidental changes to the calibration and configuration of the transmitter. When activated, the transmitter will allow all read functions to read normally. If an attempt is made to change a value, “**Ed**” will display followed by the Numeric Display ready for the code to be entered. A proper code will unlock the transmitter and the transmitter will return to the last function attempted. Any incorrect value will result in “**bAd**” briefly displaying. The transmitter will then return to numeric display and await the entry of the code. Once unlocked, the transmitter will allow access to all functions until the transmitter is either powered down or no key-strokes are made for a period of 2 minutes. If the code should be forgotten, pressing and holding the **ACCESS** key for 5 seconds will result in display of the code. Releasing the **ACCESS** key, then pressing **ENTER** will unlock the transmitter.

6.1.1 Keyboard Security (**Ed**).

1. Enter Set Mode by pressing the **ACCESS** key twice
2. Press the **SCROLL** (**▲**) key until “**Ed**” appears on the display.
3. Press the **SELECT** (**◀**) key.
4. Use the **SCROLL** (**▲**) and **SELECT** (**◀**) keys to display the desired value, then **ENTER** it into memory.

NOTE

Entering “**000**” disables the keyboard security.

NOTE

Security feature will not activate until 2 minutes without keyboard activity or power is removed from the transmitter, then restored.

SECTION 7.0 THEORY OF OPERATION

7.1 GENERAL.

The MODEL 20-03 Dissolved Oxygen Transmitter automatically and continuously measures concentrations of dissolved oxygen in water or aqueous solutions. The determination is based on the measurement of the electrical current developed by the DO Sensor in contact with the sample.

7.1.1 Basic DO Measurement.

1. Dissolved Oxygen - The amount of gaseous oxygen, in mg/L, or ppm by weight, dissolved in a liquid (usually H₂O). The presence of dissolved solids affects the solubility of oxygen in water.
2. The amount of oxygen dissolved in fresh water at 100% saturation is inversely proportional to the temperature, and is directly proportional to the pressure.
3. At sea level and a temperature of 20°C, an oxygen saturated solution of water contains 9.1 ppm (parts per million) of oxygen. The value of 9.1 ppm represents the weight of oxygen with respect to the weight of water.
4. A polarographic oxygen sensor measures oxygen in air as well as in water. In fact, most sensors are air calibrated prior to water measurements.
5. The mineral content of a given water solution will also alter the amount of dissolved oxygen. For example, salt water in the ocean at 20°C contains only 7.4 ppm of dissolved oxygen compared to fresh water which contains 9.1 ppm. This difference may account for the fact that some fish cannot survive when moved from fresh to salt water and vice versa.

7.2 MEASUREMENT VARIABLES.

Variables that influence the dissolved oxygen measurement include barometric pressure, relative humidity, sample temperature, interfering gases and composition of the liquid medium.

7.2.1 Barometric Pressure and Relative Humidity.

Rate of oxygen diffusion through the sensor mem-

brane, and therefore the sensor response, is linear with respect to oxygen partial pressure (assuming constant sample temperature).

At the normal sea-level barometric pressure of 760 mm Hg, the oxygen partial pressure of dry air is 160 mm Hg. As atmospheric pressure deviates from the standard value, the oxygen partial pressure varies proportionally. Accordingly, the solubility of oxygen in water varies in proportion to the change in the partial pressure of oxygen in air. Barometric pressure is therefore a significant factor in transmitter calibration.

In the PPM mode the barometric pressure is only important for air calibration, so the instrument can calculate the sensor's output at a known partial pressure. In process, the direct measurement of ppm is not affected by partial pressure.

In the % SAT mode, barometric pressure must be known for air calibration and for process measurement at atmospheric pressure.

7.2.2 Relative Humidity.

In calibration for dissolved oxygen measurement, one method is to expose the sensor to a gaseous sample, typically dry air, of accurately known oxygen content. The known gaseous oxygen concentration value is then related to a corresponding dissolved oxygen value.

Since dry air contains 20.95% oxygen by volume, regardless of the barometric pressure, oxygen can be shown to be directly proportional to the total barometric pressure, according to Dalton's law of partial pressures. Thus for dry air, if the total barometric pressure is known, the partial pressure of oxygen can be computed. However, this procedure is valid only for dry air conditions. Humid air has the effect of reducing the partial pressure of oxygen and the other gases in the air without affecting the total barometric pressure.

Thus, for constant barometric pressure, if the humidity in the air is other than zero, the partial pressure of oxygen is less than the value for dry air. For most measurements taken below 80°F (26.7°C), the effect of water vapor may be ignored.

To determine the partial pressure of oxygen in air at various levels of humidity and barometric pressure, the partial pressure of water is subtracted from the total barometric pressure and the difference is multiplied by 20.95%.

EXAMPLE:

If the Barometric pressure = 740 mm Hg
 and the Partial Pressure H₂O = 20 mm Hg
 then the Partial pressure O₂ = [740 - 20] x 0.2095 mm Hg
 = 150 mm Hg (19.95 kPa)

7.2.3 Sample Temperature.

The temperature of the sample affects sensor response in two ways:

1. Oxygen Diffusion Rate — The rate of oxygen diffusion through the sensor membrane varies with temperature at a coefficient of about +3% per degree Celsius, causing a corresponding change in sensor current.

2. Oxygen Solubility — In an oxygen-saturated liquid, partial pressure of dissolved oxygen is equal to the partial pressure of oxygen in the atmosphere above liquid. This relationship holds true regardless of the oxygen concentration. As sample temperature increases, oxygen partial pressure remains unchanged (except as influenced by vapor pressure of the liquid); however, the dissolved oxygen concentration is reduced.

To compensate for temperature, the MODEL 20-03 transmitter uses the thermistor (22KΩ at 25°C) incorporated in the OxyProbe Sensor. As the sample temperature changes, the thermistor resistance changes affecting the signal gain to the transmitter. The MODEL 20-03 compensates for membrane permeability in both the % SAT and the ppm mode, and corrects for oxygen solubility in the ppm mode.

7.2.4 Interfering Gases.

Gases that are reduced or oxidized at about 0.67 VDC, and thus contribute to sensor current, may cause a readout error. Only a few gases have this characteristic. Common gases that should be avoided include SO₂, Cl₂ and oxides of nitrogen. Low-level concentrations of hydrogen-sulfide tend to contaminate the sensor, but do not seriously affect dissolved oxygen measurement. If contaminated, the sensor must be rejuvenated.

7.2.5 Composition of the Liquid Medium.

A significant change in the composition of the solution may change the solubility of oxygen. If the solvent is water, the addition or presence of any water soluble components, such as sodium chloride, may change the dissolved oxygen concentration.

In an open equilibrating system, where gas of constant oxygen partial pressure is in direct contact with a salt solution, the solubility of oxygen decreases as salinity increases.

SECTION 8.0 DIAGNOSTICS AND TROUBLESHOOTING

8.1 DIAGNOSTICS. The MODEL 20-03 Transmitter has a diagnostic feature which automatically searches for fault conditions that would cause an error in the measured dissolved oxygen value. If such a condition occurs, the current output and relays will act as configured in default and the fault flag and display will flash. A fault code mnemonic will display at frequent intervals. If more than one fault condition exists, the display will sequence the faults at eight second intervals. This will continue until the cause of the fault has been corrected. Display of fault mnemonics is suppressed when in Set Mode. Selecting the “5H0” item will display a history of the two most recent fault conditions unless “5H0” was cleared. Refer to Section 4.10.

NOTE

If the transmitter is in hold and a fault occurs, the mnemonic “HLd” will display during the fault sequence.

8.1.1 Fault Mnemonics. Table 8-1 lists the fault mnemonics and describes the meaning of each.

8.1.2 Temperature Compensation. Table 8-2 is a ready reference of Thermistor resistance values at various temperatures. These are used for test and evaluation of the sensor.

NOTE

Ohmic values are read across the Thermistor element and are based on the manufacturer’s stated values ($\pm 1\%$). Allow enough time for the Thermistor element to stabilize to the surrounding temperature.

TABLE 8-1. Fault Mnemonics

Display	Description	Display	Description
EEP	EEPROM write error (bad EEPROM chip).	tcH	High temperature compensation error.
CHS	ROM failure (check sum error) (bad ROM chip).	tcL	Low temperature compensation error.
rci	Reverse current input.	Orn	Over range error (+20.00 ppm).
SEn	Sensor line error or wire length error.	EcI	Excessive current input.
COP	Computer not operating properly.	FAC	Factory calibration required.

TABLE 8-2. Thermistor Resistance Values

Temperature	Resistance	Temperature	Resistance
0°C	64.9 KΩ	50°C	8.57 KΩ
10°C	41.3 KΩ	60°C	6.07 KΩ
20°C	27.0 KΩ	70°C	4.38 KΩ
25°C	22.0 KΩ	80°C	3.21 KΩ
30°C	18.0 KΩ	90°C	2.39 KΩ
40°C	12.3 KΩ	100°C	1.80 KΩ

8.2 TROUBLESHOOTING.

The MODEL 20-03 Transmitter is designed with state-of-the-art microprocessor circuitry, making troubleshooting simple and direct. Subassembly replacement, i.e. printed circuit board replacement, is all that is usually required.

8.2.1 Installation Failure. If failure does occur, complete the following steps:

1. Check for sensor failure first.
2. Check for a fault flag. If a fault condition exists, refer to Table 8-1 for the fault mnemonic explanation.
3. Check wiring connections for proper installation
4. Refer to Troubleshooting Table 8-3. The table is arranged with the most common problems listed first.

8.2.2 Display Test. Display Mnemonic "dE5". Selecting this option will activate all the display segments. This item is used if a faulty display is suspected. Refer to Section 4.12.

8.2.3 Software Version. Display Mnemonic "UEr". Selection of this item will display the software revision level of the CPU. This number may be requested by factory service personnel if troubleshooting is required. Refer to Section 4.11.

8.2.4 Sensor Troubleshooting. In addition to the fault mnemonics that directly relate to a possible sensor problem (5En, EcH, EcL), the transmitter can display the nanoamp input from the sensor. This information can aid in sensor and application problems.

1. Enter Set Mode by pressing the **ACCESS** key twice.
2. Press the **SCROLL** (▲) key until "i n" appears on the display.
3. Press the **SELECT** (◀) key. The current input from the sensor will be displayed in nanoamps. A properly operating sensor will produce approximately 6.4 nanoamps per ppm at 25°C.
4. Press the **ENTER** key to return to the first level of the Set Menu, or press the **DO** key to get out of the 5Et Mode.

8.2.5 CPU Board Replacement. If there is a problem with the CPU board resulting in its replacement, specific procedures (included with the order) for calibrating the new board must be followed exactly or the microprocessor will be improperly programmed. Should this occur, it will be necessary to return the transmitter to the factory for reprogramming.

8.2.6 Power Board Replacement. If it becomes necessary to replace the power board, the CPU board will need to be recalibrated following specific procedures that are included with the power board. Failure to follow these procedures exactly will cause the microprocessor to be improperly programmed and require the return of the transmitter to the factory for reprogramming.

TABLE 8-3. Troubleshooting Guide

SYMPTOM	PROBLEM	ACTION
Fault code "E _{CH} " / "E _{CL} "	1. Miswire. 2. Open or shorted Thermistor.	1. Check wiring between the sensor and transmitter. 2. Replace sensor.
Fault code "O _{rn} " / "E _{ci} "	1. Over range error.	1a. Pull the sensor out of the process, clean, and check membrane. 1b. Recalibrate.
Fault code "SE _n "	1. Open wire between sensor and transmitter. 2. Cable length has been exceeded. Maximum length: 60 ft. (18 m).	1. Repair wire. 2. Check wiring.
Fault code "EEP"	1. Defective EEPROM.	1. Replace CPU PCB.
Fault code "CH ₅ "	1. Defective CPU.	1. Replace CPU PCB.
Alarm relay will not close	1. Defective power card. 2. Defective CPU.	1. Replace power PCB. 2. Replace CPU PCB.
No output current	1. Defective output board. 2. Miswire.	1. Replace power PCB. 2. Check for short.
Low output current	1. Circuit loading with excessive resistance on output.	1. Consult output loading limits. Transmitter specifications: (600 ohms max load).
Reading loses accuracy as process temp. changes	1. Incorrect temp. compensation.	1. Verify Sensor Function (Refer to OxyProbe® Sensor Manuals P1431 and P1806.)

TABLE 8-4. Replacement Parts and Accessories

P/N	DESCRIPTION	P/N	DESCRIPTION
AM-9227	Gasket, Rear cover	AM-9260	Fuse, 0.1A, 3AG, 250V, Slo Blo
AM-9228	Gasket, Front Cover	AM-9262	Front Panel MODEL 20-03
AM-9229	PCB, Power Supply	AM-9295	Enclosure
AM-9248	PCB, Mother Board	AM-9296	Enclosure, Rear Cover
AM-9252	PCB, LED Digital Display	AM-9298	PCB, CPU BJC D.O.

SECTION 9.0 RETURN OF MATERIALS

9.1 GENERAL.

To expedite the repair and return of sensors, proper communication between the customer and the factory is important. A return material authorization (RGM number) is required. Call (714) 829-5555 or FAX (714) 829-5560. The "Return Goods Memo" form is provided for you to copy and use in case the situation arises. The accuracy and completeness of this form will help to expedite the processing time of your materials.

9.2 WARRANTY REPAIR.

The following is the procedure for returning products still under warranty.

1. Contact the factory for authorization..
2. Complete a copy of the "Return Goods Memo" form as completely and accurately as possible.
3. To verify warranty, supply the factory sales order number or the original purchase order number.
4. Carefully package the materials and enclose the completed copy of the "Return Goods Memo" form. If possible, pack the materials in the same manner as received.

IMPORTANT

Please see second section of the "Return Goods Memo" form. Compliance to the OSHA requirements is mandatory for the safety of all personnel. MSDS forms and a certification that the sensors have been disinfected or detoxified are required.

5. Send the package prepaid to:

Broadley-James Corporation

19 Thomas

Irvine, CA 92618

Attn: Factory Repair

Mark the package:

Returned for Repair RGM No. _____

Model No. _____

9.3 NON WARRANTY REPAIR.

1. Contact the factory for authorization.
2. Fill out a copy of the "Return Goods Memo" form as completely and accurately as possible.
3. Include a purchase order number and make sure to include the name and telephone number of the right individual to be contacted should additional information be needed.
4. Do Steps 4 and 5 of Section 9.2.

NOTE:

Consult the factory for additional information regarding service or repair.

NOTES

RETURN OF MATERIALS REQUEST

●IMPORTANT!

This form must be completed to insure expedient factory service

CUSTOMER	RETURN TO: _____	BILL TO: _____
	_____	_____
	_____	_____
KEY CONTACT		
NAME _____		PHONE _____
ADDRESS _____		

NOTICE TO SENDER

CUSTOMER/USER MUST SUBMIT MATERIAL SAFETY SHEET (MSDS) OR COMPLETE STREAM COMPOSITION, AND/OR LETTER CERTIFYING THE MATERIALS HAVE BEEN DISINFECTED AND/OR DETOXIFIED WHEN RETURNING ANY PRODUCT, SAMPLE OR MATERIAL THAT HAS BEEN EXPOSED TO OR USED IN AN ENVIRONMENT OR PROCESS THAT CONTAINS A HAZARDOUS MATERIAL. ANY OF THE ABOVE THAT IS SUBMITTED TO BROADLEY-JAMES CORPORATION WITHOUT THE MSDS WILL BE RETURNED TO SENDER C.O.D. FOR THE SAFETY AND HEALTH OF OUR EMPLOYEES. WE THANK YOU IN ADVANCE FOR COMPLIANCE TO THIS SUBJECT.

COMPONENT OR SUB-ASSEMBLY:	MODEL NUMBER:	SERIAL NUMBER:
1. PART NO. _____	1. MODEL _____	1. SER NO. _____
2. PART NO. _____	2. MODEL _____	2. SER NO. _____
3. PART NO. _____	3. MODEL _____	3. SER NO. _____

REASON FOR RETURN

PLEASE CHECK APPROPRIATE BOX(ES):

<input type="checkbox"/> WRONG PART RECEIVED	<input type="checkbox"/> WARRANTY REQUEST
<input type="checkbox"/> DUPLICATE SHIPMENT	<input type="checkbox"/> NON-WARRANTY (CUSTOMER P.O.# _____)
<input type="checkbox"/> REPAIR AND CALIBRATE	<input type="checkbox"/> DEMO EQUIPMENT NO. _____
<input type="checkbox"/> EVALUATION	<input type="checkbox"/> OTHER (EXPLAIN) _____
<input type="checkbox"/> REPLACEMENT REQUIRED	_____

DESCRIPTION OF APPLICATION:

DESCRIPTION OF MALFUNCTION:

REPAIR STATUS

YES/ REFERENCE ORIGINAL BROADLEY-JAMES ORDER NO. _____

CUSTOMER REPAIR PURCHASE ORDER NO. _____

NO/ CONTACT WITH ESTIMATE OF REPAIR CHARGES: _____

NAME OF CONTACT: _____

FAX _____

PHONE _____



RGM NUMBER: _____
(ASSIGNED BY THE BJC FACTORY)

WARRANTY

Goods and part(s) manufactured by Seller are warranted to be free from defects in workmanship and material under normal use and service for a period of twelve (12) months from the date of shipment by Seller. Goods and part(s) proven by Seller to be defective in workmanship and / or material shall be replaced or repaired, free of charge, F.O.B. Seller's factory provided that the goods and part(s) are returned to Seller's designated factory, transportation charges prepaid, within the twelve (12) month period of warranty. This warranty shall be in effect for replacement or repaired goods and part(s) for the remaining portion of the period of the twelve (12) month warranty. A defect in goods or part(s) of the commercial unit shall not operate to condemn such commercial unit when such goods and part(s) are capable of being renewed, repaired or replaced.

The Seller shall not be liable to the Buyer, or to any other person, for the loss or damage, directly or indirectly, arising from the use of the equipment or goods, from breach of any warranty or from any other cause. All other warranties, expressed or implied are hereby excluded.

IN CONSIDERATION OF THE STATED PURCHASE PRICE OF THE GOODS, SELLER GRANTS ONLY THE ABOVE STATED EXPRESS WARRANTY. NO OTHER WARRANTIES ARE GRANTED INCLUDING, BUT NOT LIMITED TO, EXPRESS AND IMPLIED WARRANTIES OF MERCHANTABILITY AND FITNESS FOR A PARTICULAR PURPOSE.

RETURN OF MATERIAL

Material returned for repair, whether in or out of warranty, should be shipped prepaid to:

**Broadley-James Corporation
19 Thomas
Irvine, CA 92618 USA**

The shipping container should be marked:

"Return for Repair"

Model: _____

RGM Nr: _____ (must be obtained from the factory prior to return)

The returned material should be accompanied by a letter of transmittal which should include the following information (make a copy of the "Return of Materials Request" found on the last page of the Manual and provide the following thereon):

1. Location type of service, and length of time of service of the device.
2. Description of the faulty operation of the device and the circumstances of the failure.
3. Name and telephone number of the person to contact if there are questions about the returned material.
4. Statement as to whether warranty or non-warranty service is requested.
5. Complete shipping instructions for return of the material.

Adherence to these procedures will expedite handling of the returned material and will prevent unnecessary additional charges for inspection and testing to determine the problem with the device.

If the material is returned for out-of-warranty repairs, a purchase order for repairs should be enclosed.

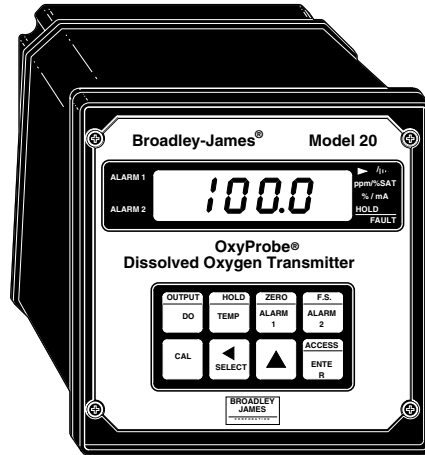
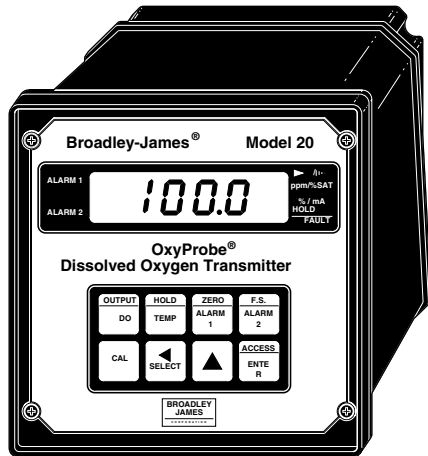
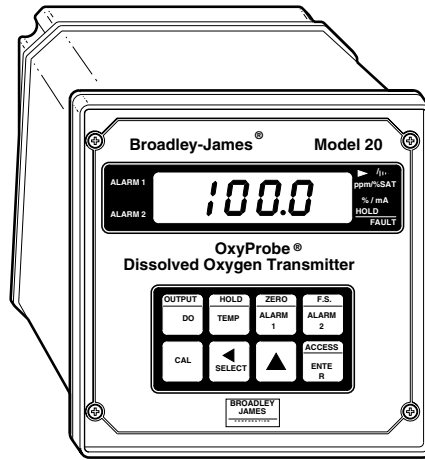
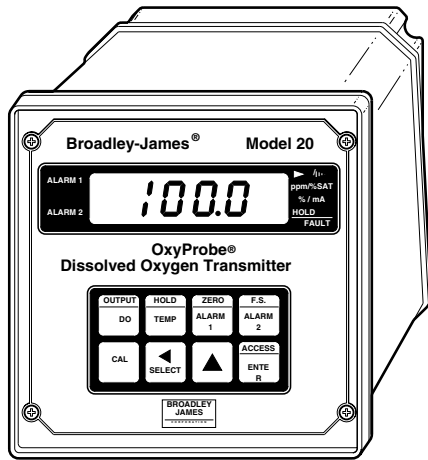

**BROADLEY
JAMES**
CORPORATION

CE